

WELLS TOWNSHIP RECREATION PLAN 2024-2028



WELLS TOWNSHIP

TOWNSHIP BOARD RESOLUTION

WELLS TOWNSHIP

PLANNING COMMISSION RESOLUTION

**Wells Township Parks and Recreation Plan
Recommendation of Support to Adopt the 5-Year Recreation Plan
For Wells Township
Marquette County
January 23rd, 2023**

WHEREAS, the Wells Township Planning Commission has undertaken a planning process to determine the recreation and natural resource conservation needs and desires of its residents during a 5-year period covering the years of 2023 through 2027, and

WHEREAS, the Planning Commission is made up of representatives by citizens of the Township, and

WHEREAS, the Commission began the process of developing a community recreation plan in accordance with the most recent guidelines developed by the Department of Natural Resources and made available to local communities, and

WHEREAS, the public was given a well-advertised opportunity and reasonable accommodations to review the final draft plan for a period of at least 30 days, and

WHEREAS, the Commission has developed the plan as a guideline for improving recreation and enhancing natural resource conservation for Wells Township, and

NOW, THEREFORE BE IT RESOLVED the Wells Township Planning Commission hereby recommends to the Township Board to adopt the final draft plan as presented.

Yeas: 5
Celina Sundholm
Steve Miteski
Lori Lynch
Barb Roberts
Kathy Brady

Nays: 0

Absent: 0

1-23-23

Date



WELLS TOWNSHIP

CONTENTS

- 1 INTRODUCTION** | A VISION FOR PARKS AND RECREATION IN WELLS TOWNSHIP
 - 2 COMMUNITY DESCRIPTION** | DESCRIPTION, DEMOGRAPHICS + DATA
 - 3 ADMINISTRATIVE STRUCTURE, BUDGET + VOLUNTEERS**
 - 4 NATURAL ENVIRONMENT** | LANDSCAPE FEATURES, SOILS, VEGETATION, + WILDLIFE
 - 5 RECREATION INVENTORY**
 - 6 COMMENTS + ISSUES SCOPING**
 - 7 VALUES, GOALS + OBJECTIVES**
 - 8 ACTION PLAN** | PRIORITY PROJECTS
- APPENDIX A** | PUBLIC NOTICE + COMMUNITY SURVEY RESULTS
- APPENDIX B** | GRANT HISTORY
- APPENDIX C** | UNIVERSAL ACCESS DESIGN GUIDELINES

1

INTRODUCTION

5-YEAR RECREATION PLAN

Every 5 years communities throughout Michigan update their recreation plans to ensure qualification for annual Michigan Department of Natural Resources (MDNR) funding opportunities.

The 5-year recreation plan must adhere to a format defined by the MDNR and outline priority goals, objectives, and projects with the potential to be completed within the 5-year window and beyond.

This document synthesizes data on natural resources, community demographics, existing recreation assets, operational management, citizen input, and community partnerships to generate an all-inclusive map for recreation in the community. It describes community values, highlights common goals and objectives, and outlines strategies to achieve these goals.

Looking beyond the 5-year window, this document will serve as a road map for future endeavors improving parks for decades to come. The 2024-2028 Recreation Plan will assist officials in determining priority projects to nurture an already expansive parks system. It will outline strategies for making parks accessible to all and provide park designs that allow future generations to grow and prosper within.



Covid-19 and its many variants wreaked havoc on everything we knew to be normal from riding the bus to school in the morning to picking up a cup of coffee at the local shop. Despite these irksome new Covid wary habits, there is at least one silver lining. The outdoors have become our safe haven, friend and family gathering space and vacation destination. The Upper Peninsula of Michigan tourism industry has exploded, boosting local economies.

Years later, campsites continue to book up well in advance and demand for trail and recreation infrastructure is consistent throughout Michigan's Upper Peninsula.

A report prepared by the MEDC by Tourism Economics in 2014, found direct spending by leisure travelers equated to \$16.6 billion-nearly 73% of all visitor spending in Michigan. As this report demonstrates, local economies are stimulated by access to recreation opportunities in addition to improving a community's health and vitality.

Let's keep this momentum going!



PLANNING PROCESS

RECREATION PLAN

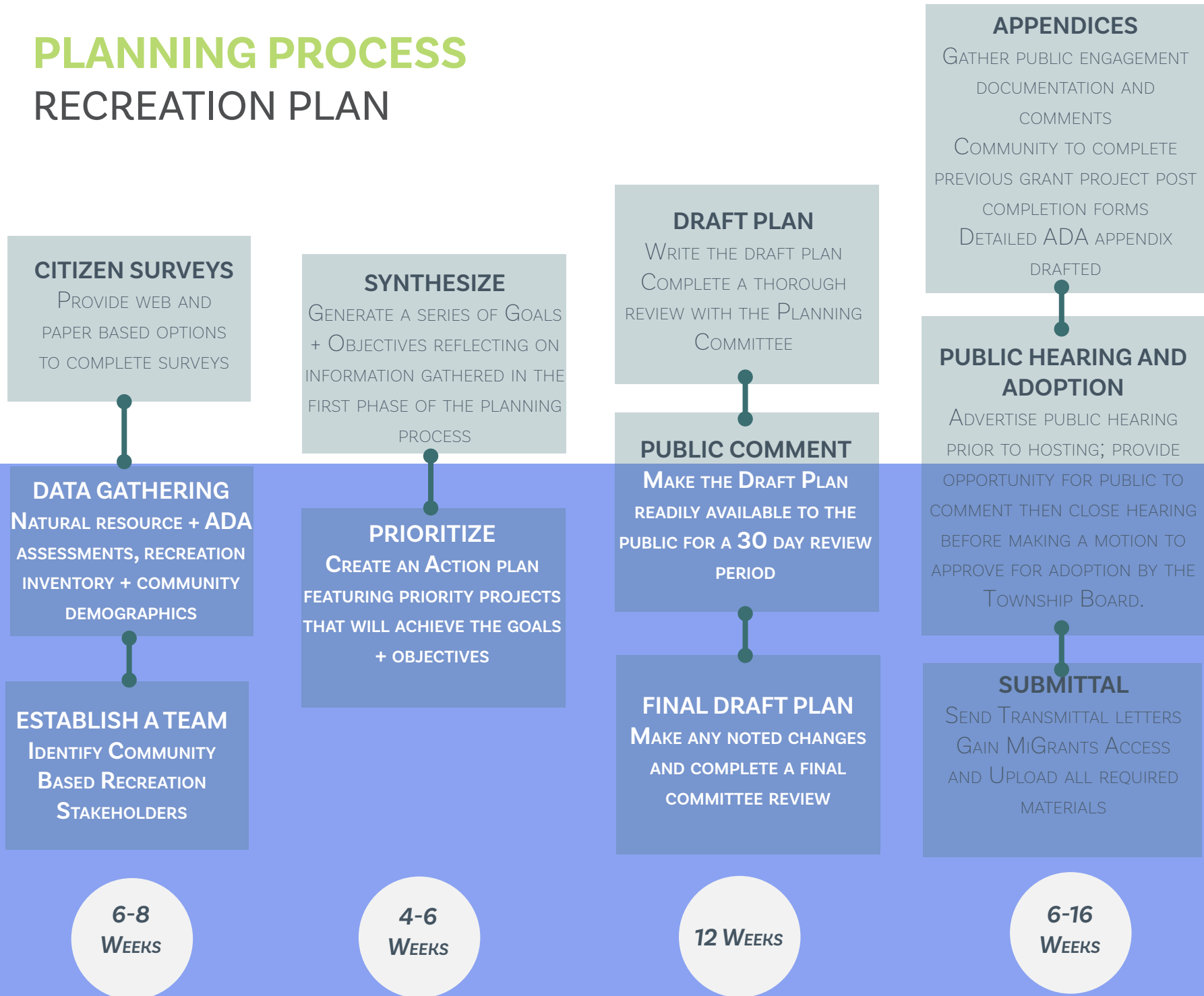

2 COMMUNITY DESCRIPTION

WELLS TOWNSHIP

Wells Township is located along the southern border of Marquette County in Michigan's Upper Peninsula. It contains 155 square miles with nearly 1/3 of the property under state ownership.

Wells Township was officially organized in 1903 from land belonging to Forsyth Township. Early homesteaders in the area maintained a livelihood by farming and cutting timber. Logging camps were operating in the area in the mid-1850s, northeast of Watson. Oxen were used to deliver supplies to the camps via a tote road that started in the Cornell area - known today as the Boney Falls Road. The Escanaba and Lake Superior Railroad constructed a station in Watson in 1899, which opened up the area for settlement. Railroad expansion allowed for stations to be developed in Mashek, Reade, Northland, Ross, and Gleason. Northland was founded in 1897 by the Wolverine Cedar & Lumber Company, in anticipation of the expanding railroad.

George Mashek and his partner, Ed Arnold, owned a logging camp

at Watson in the area of the present Jaeger house. In 1908, a store, boarding house, warehouse and saloon were established. Mashek's general store included a post office area which opened in 1909. Since a downstate community was already using Watson for a post office name, the name Arnold was substituted. In 1935, the post office was relocated to the store at the corner of CR 426 and CR 557. Following the height of the logging era, people who settled in the area made their livelihoods principally by farming. Most farming was done on a small scale supplemented with animals, gardens, and timber cutting.

Today, like it was then, distance continues to be an issue for township residents. Opportunities that once existed for workers in the logging industry are limited. Many of the current residences are for seasonal use and serve as secondary homes. People come to this region in hopes of finding a peaceful place where nature is abundant and access to the outdoors is readily available.



ORV/SNOWMOBILE TRAIL



WELLS TOWNSHIP SCHOOL

WELLS TOWNSHIP AS IT RELATES TO RECREATION

	YEAR	1960	1970	1980	1990	2000	2010	2020	PERCENT CHANGE 1960-2020
WELLS TOWNSHIP:	POPULATION	278	277	351	281	292	231	213	-0.8%
MARQUETTE COUNTY:		56,154	64,686	74,101	70,887	64,634	67,077	66,017	+1.2%

Assessing the number of people in the community and their demographic characteristics helps planners and policy makers to determine the needs of the community. For recreation planning, population data is useful when applying recreation standards to a community.

Wells Township has seen a decrease in population within the past twenty years from 272 people in 2000 to 213 in 2020. The median age within the township is 59. In comparison the median age in Marquette County is 39.5 indicating a much older population within the township.

Understanding the composition of the population by age will help leaders plan for the types of recreation and facilities that will maximize opportunity for as many residents as possible. In the pie charts shown below, Wells Township's 60+ population percentage has more than doubled and the 25 and under population has been cut in half. This indicates a rapidly aging demographic. 21% of the population indicated having a disability within the 2020 census data which is quite high compared to other area communities.

Wells Township has done a great job of providing accessible routes to their township hall and park amenities. The township must continue to implement accessibility upgrades as projects are completed, meeting universal accessibility standards wherever possible. Maintaining cleared access paths throughout the winter and providing an accessible winter recreation option would be a great asset for the community and its residents of all ages and ability levels.

Source: US Census ACS Data

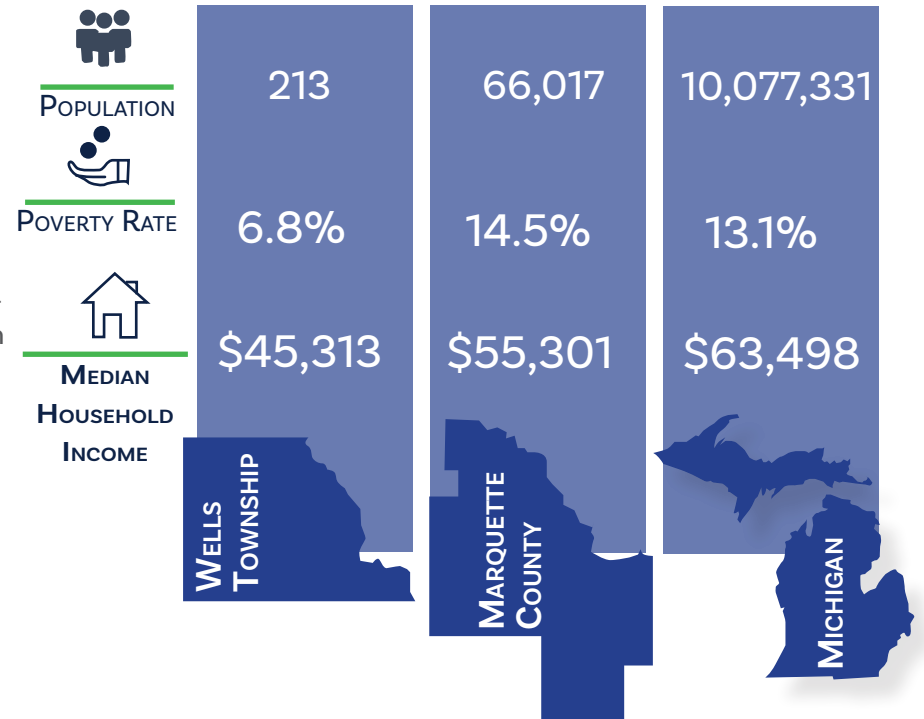

AGE | 2020

Source: US Census ACS Data

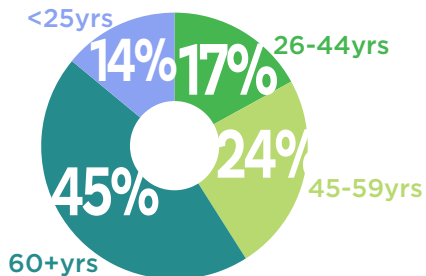

AGE | 2000

Source: US Census ACS Data

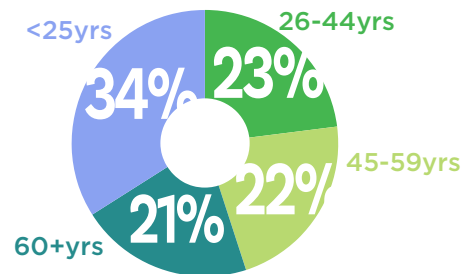

3 ADMINISTRATIVE STRUCTURE



2022 KEY FINDINGS

The National Recreation And Park Association [NRPA] has assembled a 2022 Agency Performance Review featuring park metrics throughout the nation. The goal of this document is to help local park systems identify the optimal mix of facilities and programming for their community. Key 2022 findings are listed below:

95% of Park + Recreation Agencies have Playgrounds



10.4 acres of parkland for every 1,000 residents

Residents per Park:

2,323



Full-Time Equivalent Employees (FTEs) per 10,000 Residents:

8.9



Annual Operating Expenditures per Capita:

\$93.01

14 miles of silent sport trails



Key programming activities include themed special events, social recreation events, team sports, fitness enhancements classes, and health + wellness education.



Wells Township Administrative Structure + Budget

Wells Township has a 5 member Township Board and a 5 member Planning Commission. Each meet on a monthly basis. An appointed pool manager managed pool operations when the pool was in operation. The Township Board oversees parks and recreation operations. The flow chart featuring township organization is featured below.

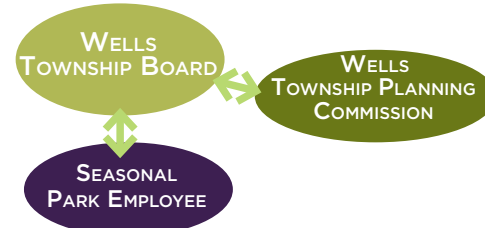

The Wells Township Parks and Recreation budget includes dedicated funds for a seasonal employee who oversees pool maintenance and operation as well as related utility bills, park mowing and maintenance, and related equipment purchases. As evidenced in the 2021-2022 budget, shown in the chart below, the township is willing to augment these funds if needed to complete priority projects. Funds for the parks and recreation budget come from the general fund. The township has received two Michigan DNR grants in the past including: a Land and Water Grant and a Michigan Bond Fund award. Tennis court improvements were completed in 2001, and funding for a pavilion was granted in 1990.

The green panel on the left reflects the most recent (2022) data gathered by the National Recreation and Park Association (NRPA) noting average spending, employee numbers, park type and quantity and other recreation related features within park systems throughout the United States. This data is presented throughout the plan to provide a gauge as to how Wells Township's parks and recreation system compares.

	2016-17	17-18	18-19	19-20	20-21	21-22
TOWNSHIP APPROPRIATION	\$15,100	\$16,000	\$13,000	\$16,250	\$16,200	\$57,500
PARKS + RECREATION BUDGET 2016-2022						

Volunteer Assistance + Involvement in the Community

The Wells Township Fire Department is staffed by volunteers. They have at least two fundraisers a year that are always supported and well attended by the community. The township has traditionally hosted community meals at the township hall during the deer hunting season and other occasions. Additionally, a monthly community meal is held at the township school. Both the school's winter holiday and spring concerts are well-attended by the community.

The township's baseball field was developed utilizing volunteer efforts and donations and the township is always eager to support community volunteer initiatives and will continue to seek assistance where needed in establishing new recreation programming and projects.



PHOTO SOURCE: WELLS TOWNSHIP VOLUNTEER FIRE DEPARTMENT FACEBOOK PAGE

4 THE NATURAL ENVIRONMENT

LANDSCAPE TYPOLOGIES

Wells Township is located in the center of Michigan's Upper Peninsula halfway between Lake Michigan and Lake Superior. It covers 155 square miles. Of that, nearly 1/3 of the township is owned by the State of Michigan. There are several landscape typologies within this rural township.

The majority of the region is covered in a mix of woody wetland and emergent wetland. It is dotted with various forest types including mixed and deciduous forests that provide shade, windbreak and habitat for recreation enthusiasts, flora and fauna. An abandoned railroad and other previously disturbed open areas are designated as shrub/scrub lands. The Wells Township Park is primarily maintained turf. Each of these landscape typologies will be explored in greater detail within this chapter. Peeling back the layers of vegetation, terrain, soils and geology is an essential step toward developing a clear understanding of the character of the township's landscape and it's potential for recreation.



MIXED FOREST



WOODY WETLANDS



DECIDUOUS FOREST



EMERGENT WETLANDS



MAINTAINED TURF



SHRUB/SCRUB

GEOLOGY + SOILS

Geology and soils provide the foundation for all forms of life and its related activities. Generating an understanding of this foundation is critical to developing a well rounded and feasible vision for future development and preservation measures.

The uppermost materials within the county were deposited by glaciers thousands of years ago. The bedrock found below this glacial drift makes up earth's crust. There is one main group of rock that makes up the mantle within Wells Township, Paleozoic. This rock dates from between 425-600 million years and consists of shallow sedimentary deposits and sandstone.¹

The Paleozoic rocks present within the township include the Black River, Prairie Du Chien, and Trempealeau Groups. Each feature a mix of sandstone, limestone and dolomites. The soil layers are primarily sandy including the Onaway series, a well-drained loam. In contrast, the Lupton series is a very poorly drained soil high in organic deposits. The Tawas series is also poorly drained and high in organic matter.

The wetland areas blanketing much of the township feature peaty soils high in organic matter. They serve as nature's sponge soaking up harmful chemicals and pollutants and reducing erosion by slowing the rate of runoff. As illustrated in the diagram above, they improve water quality by filtering and recharging groundwater reservoirs. They also provide abundant habitat for wildlife. It is necessary to preserve these natural filters as much as possible so we can continue to source clean drinking water and keep our waterbodies free from contaminants.

¹ Planning, Community Development, forestry, and Recreation Division. Welcome to Marquette County, MI. (n.d.). Retrieved December 20, 2022, from <https://www.co.marquette.mi.us/departments/planning/cuments/Programs/OGMD/Catalog/09/GIMDL-WI02I.PDF?rev=abc510020ff14000800bd065616d42ce>

HOW DO WETLANDS WORK?

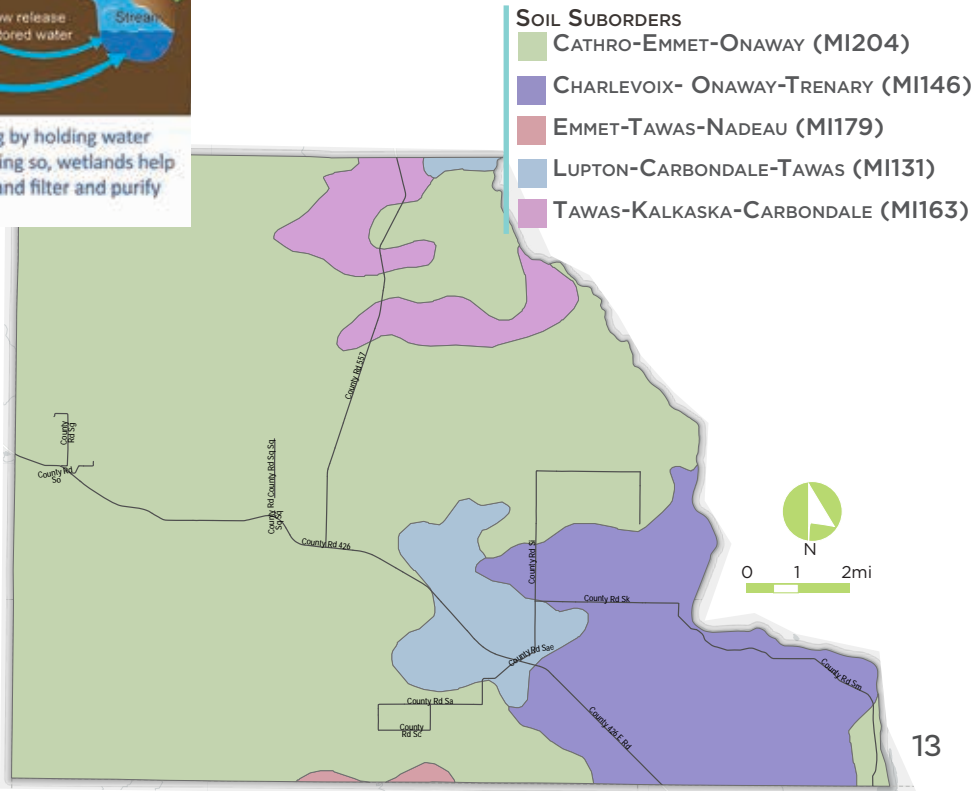
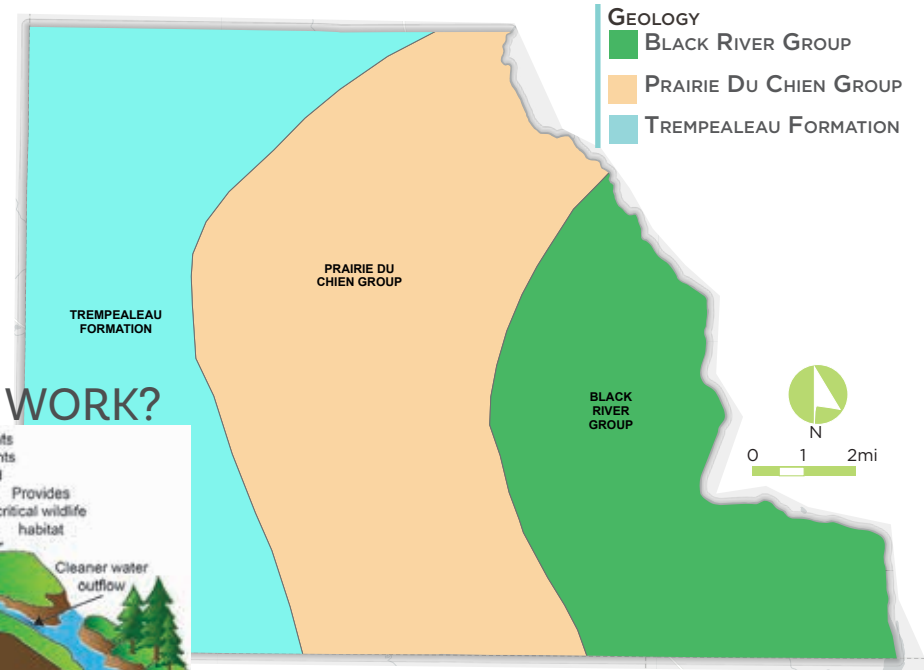
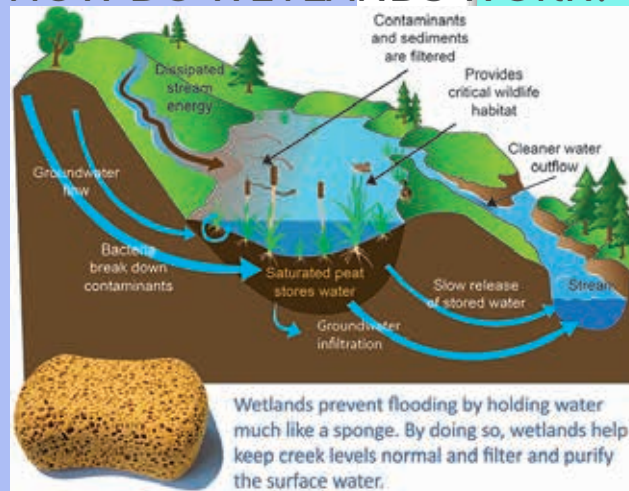

TOPOGRAPHY + HYDROLOGY

The topography within the township gradually slopes upward from the SE corner to the NW corner. As evidenced by the many low lying wetland areas, there is little undulation within the terrain and the land is primarily gently sloped or flat.

The largest water body within the township is the West Branch of the Escanaba River with the Ford River close behind. Several miles worth of creeks and smaller tributaries also traverse the terrain. These provide ample habitat for flora and fauna and excellent locations for fishing and enjoying other outdoor activities.

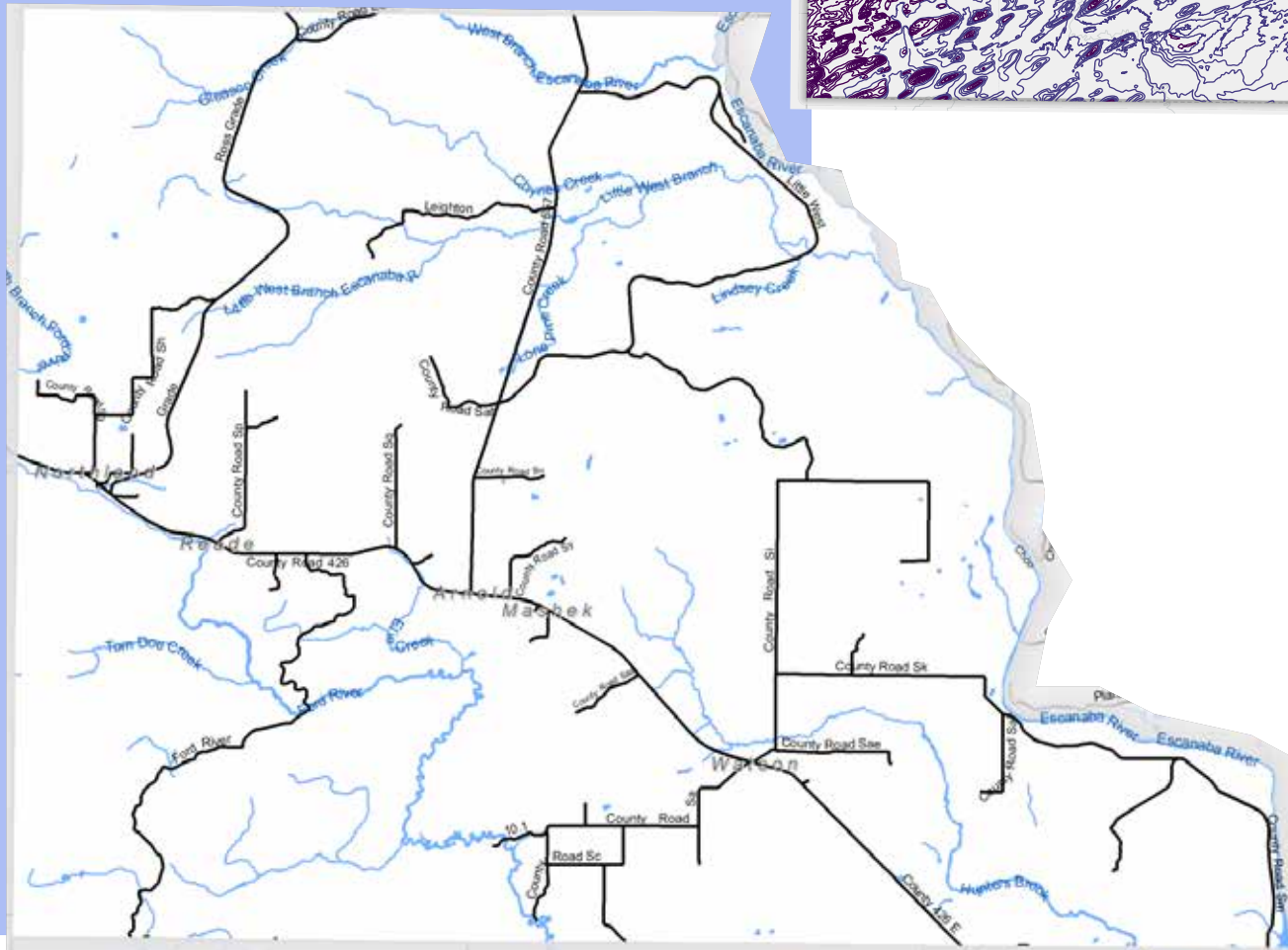
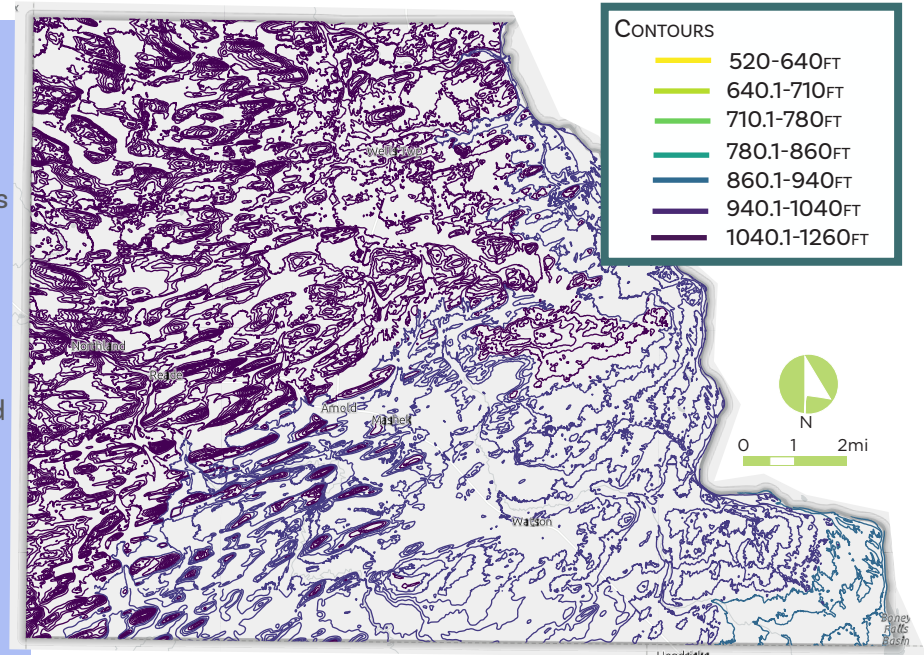

LAND COVER + WILDLIFE

The light purple in the land cover map below highlights the woody wetland areas that cover much of the township. Pockets of forest, pasture and shrub/scrub land are also present with very tiny developed areas highlighted in red. As over 30,000 acres of the township are state owned lands there is great potential to explore this otherwise tough to develop landscape.

The Information for Planning and Consultation site hosted by the U.S. Fish and Wildlife Service notes the potential existence of several threatened and endangered species within the township. Measures taken to preserve habitat and accommodate these species are critical to maintaining their existence. Water levels can impact nesting sites for Red Knot. Lynx live in boreal forests that often receive heavy snowfall and are home to snowshoe hare. Their habitat has also been destroyed leading to a decline in their population. White nose syndrome threatens the Northern Long-eared Bat. The biggest culprit threatening the Monarchs seems to be the disappearance of milkweed. It is critical communities consider these threatened and endangered species when planning for development.



LAND COVER CLASSIFICATION

- TOWNSHIP BORDERS
- OPEN WATER
- DEVELOPED AREA
- BARREN LAND (SAND + DUNES)
- DECIDUOUS FOREST
- EVERGREEN FOREST
- MIXED FOREST
- SHRUB/SCRUB
- HERBACEOUS
- HAY/PASTURE
- CULTIVATED CROPS
- WOODY WETLANDS
- EMERGENT HERBACEOUS WETLANDS

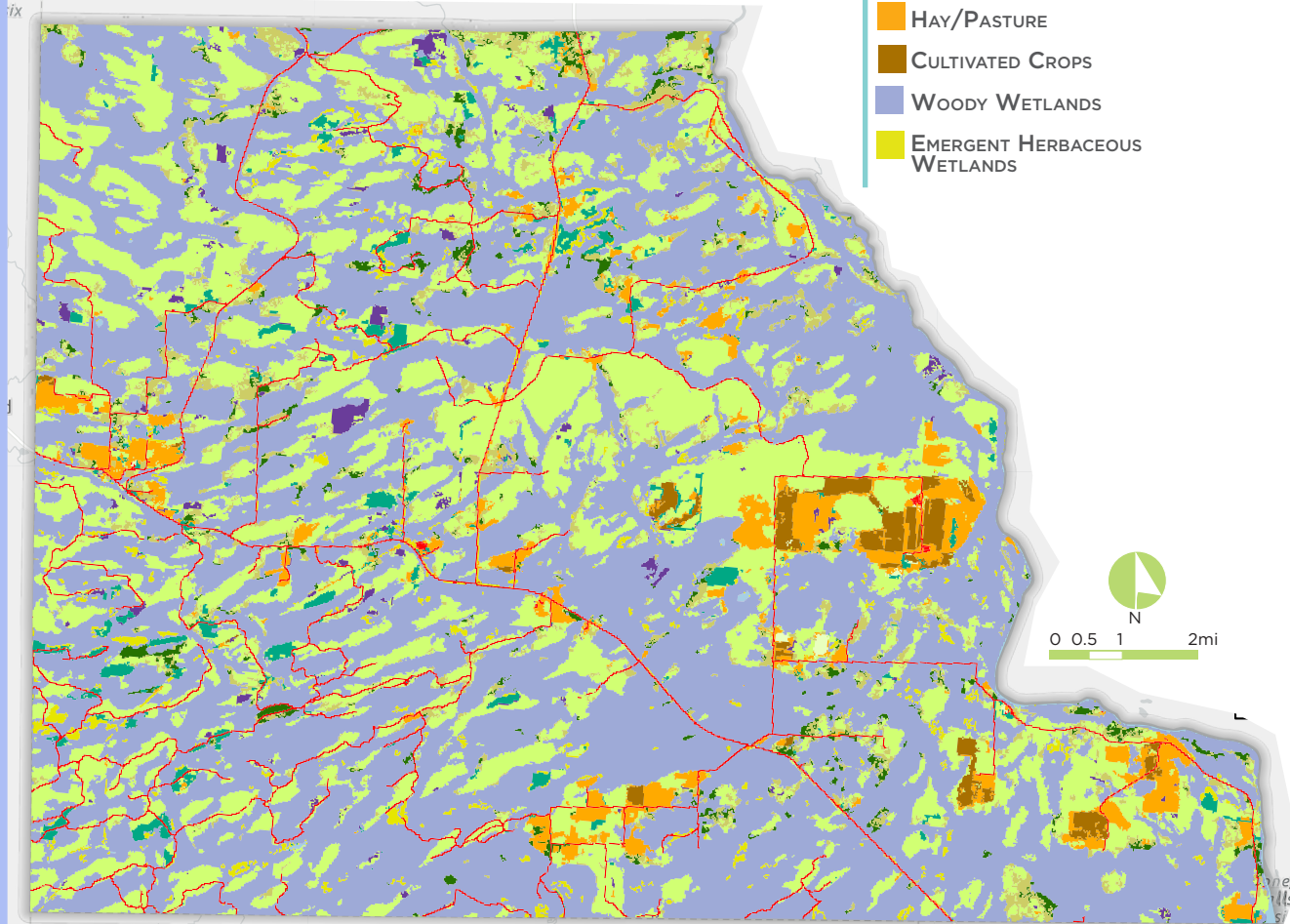

Michigan
Department of
Natural Resources
Snowmobile Trails
Marquette County

Updated: 12/6/2022



0 1 2
Miles

- P** Parking lot
- ▲** State forest campground
- x x** Temporarily closed trail
- Permanently closed trail
- Snowmobile trail
- State park boundary
- State forest land
- Federal land
- Lakes and rivers

Parking
UP33^[1] Parking off of M-35 in Gwinn just west of intersection with M-553
UP8^[2] East of Silver St, South Side of Rail St



**RIDE
RIGHT**

Michigan.gov/Snowmobiling

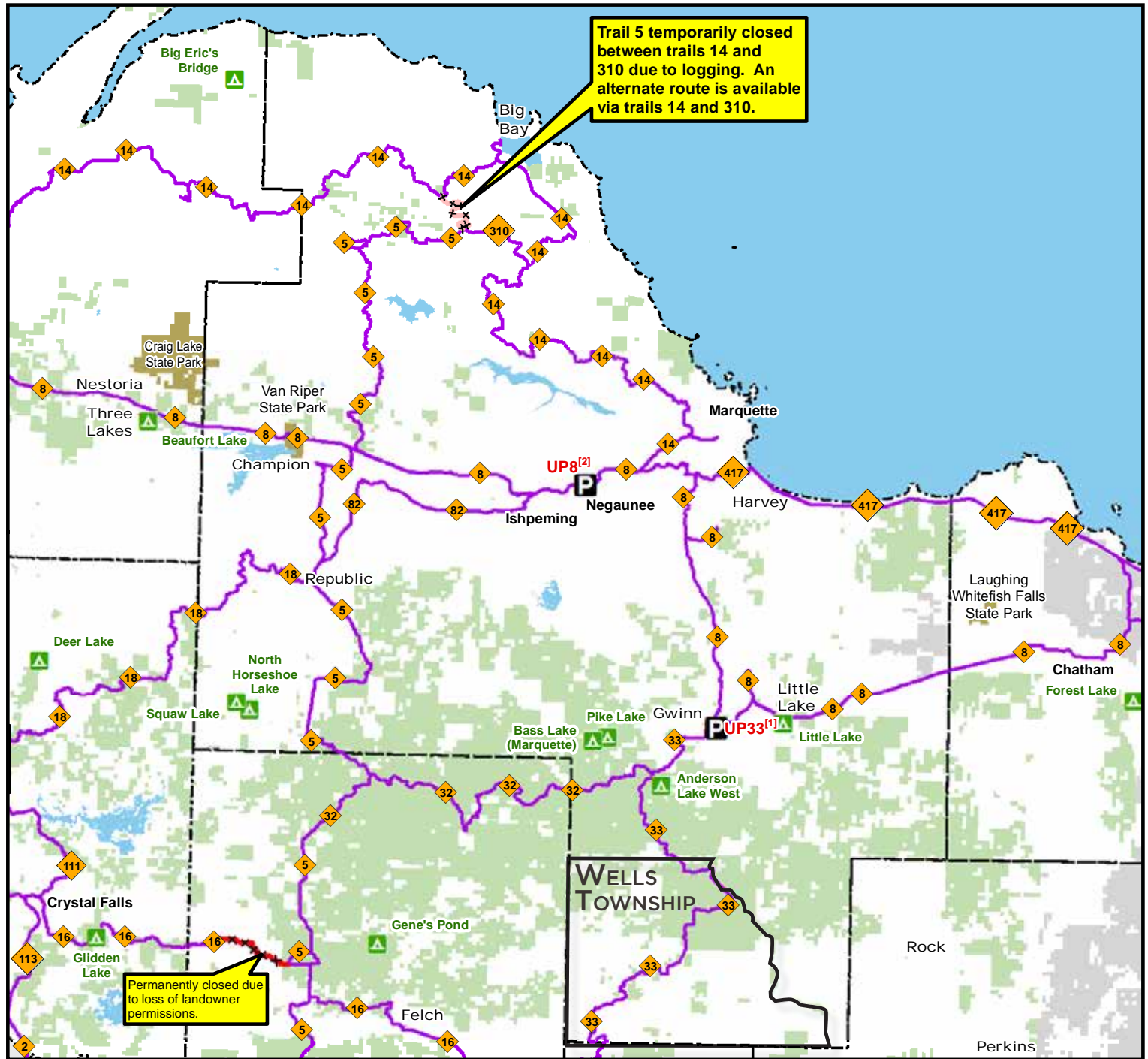

Trail 5 temporarily closed between trails 14 and 310 due to logging. An alternate route is available via trails 14 and 310.

Permanently closed due to loss of landowner permissions.

TRAILS

Roughly 25 miles of snowmobile trails run through the township via Trail 33. Much of this is also accessible via ORV. The township does participate in Marquette County's ORV Ordinance which regulates ORV traffic on County roads.

Despite nearly 1/3 of the county owned by the state of Michigan there are currently no designated non-motorized trails. Creating a non-motorized community connector trail could provide immeasurable health benefits, stimulate the economy, and allow for a safe path for students to get to school.



MDNR SNOWMOBILE/ORV TRAIL

**“MORE MOUNTAIN
BIKING AND TRAIL
INFRASTRUCTURE, INCLUDING
JUMP TRAILS, PUMP TRACK,
AND SKILLS AREA”**

-LOCAL RESIDENT

5 RECREATION INVENTORY STANDARDS FOR RECREATION

The National Recreation and Park Association (NRPA) has developed a scale to help measure an existing recreation system's park facilities and provide a baseline standard for equitable park access within a community.

A typical park and recreation system offers one park for every 2,323 residents served, with 10.4 acres of parkland per 1,000 residents. Due to its lower density population Michigan's Upper Peninsula trends toward having a higher acreage of parkland per resident. Here is a chart illustrating the different open space typologies defined by NRPA and the desired minimum amount of park space per community.

Wells Township only has one park, the Wells Township Park. This would be characterized as a community park. The school also has a playground immediately adjacent to the township park so the combination proves an excellent resource for the community.



PARK TYPE	SERVICE AREA (RADIUS)	SIZE (ACRES)	ACRES/1,000 POP	PARKS (ACRES)	USES
Mini-Park	<1/4mi	1 or less	0.25 to 0.5	Currently: --	Specialized facility serving a concentrated or limited population
Neighborhood Park	1/4 to 1/2mi	15+	1 to 2	Currently: --	Hosts intense recreation activities: Play, sports fields/courts, picnicking etc.
Community Park	1 to 2mi	25+	8 to 10	Currently: 10	Diverse environmental quality; may include sports complexes or more natural forms of outdoor recreation
Regional Park	1 hr drive	200+	5 to 10	Currently: --	Area of natural quality for outdoor recreation; boating, swimming, camping, trail use etc.
School Park				Currently: 13	Park associated with an educational institution

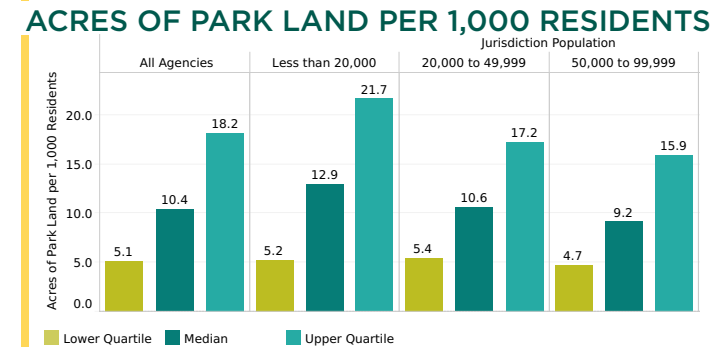
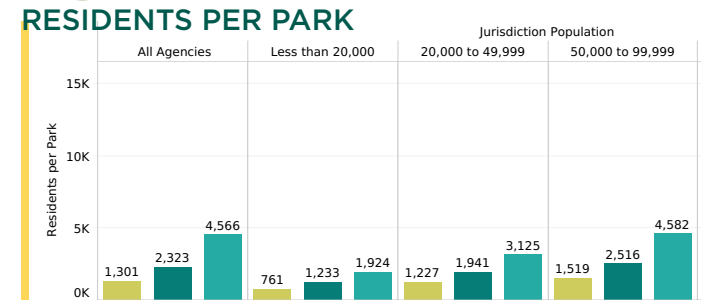

PROGRAMMING

Wells Township Hall is on the same property as the Township Park. The community readily uses the resources they have available to host town hall meetings, picnics, and community events. They also rent out the facility and pavilion for private events. The swimming pool, originally installed in 1973, was a well-loved feature of the property when it was operable. Complications from a recent rehab project have left the pool closed for an indeterminate length of time.

Recreation opportunities at the township park and school are listed in the chart below. The most common activities listed by survey participants were walking/hiking, riding ORVs, and swimming. The community is obviously eager to see their pool reopen. There is also a desire to have a community walking/bike trail.

PARK/FACILITY ACTIVITY

WELLS TOWNSHIP PARK



WELLS TOWNSHIP SCHOOL



RECREATION ACTIVITY KEY	
	Boat Facilities
	Biking
	Playground
	Ball Sports
	Picnic Area
	Sledging
	Hockey + Ice Skating
	Sightseeing + Wildlife Viewing
	Hiking + Walking
	Camping
	Mountain Biking
	Disk Golf
	Fishing
	Cross-Country Skiing
	Swimming
	Snowshoeing
	Paddling
	Arts + Culture
	Skate Park

WELLS TOWNSHIP PARKS

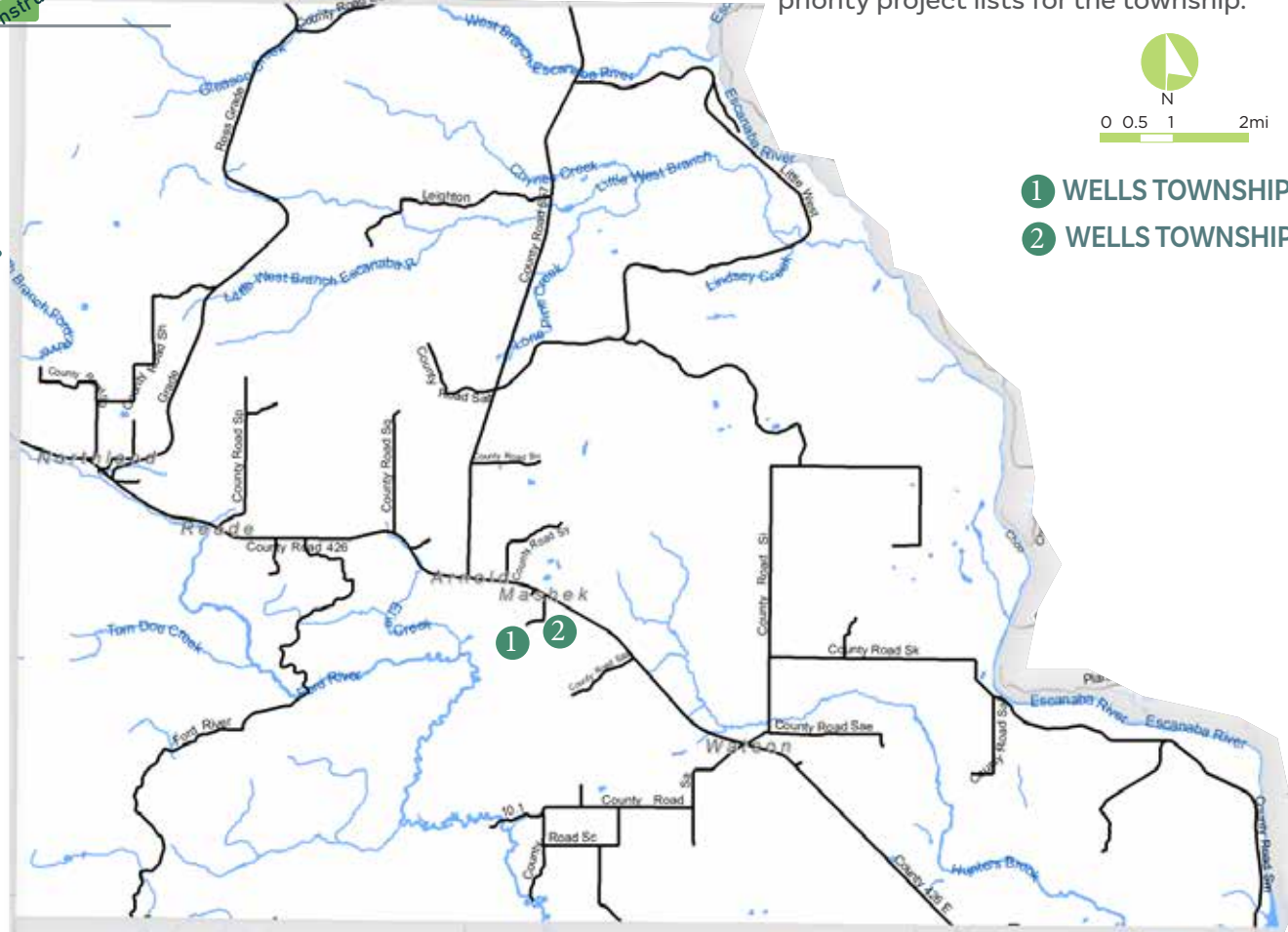

- 1 WELLS TOWNSHIP PARK
- 2 WELLS TOWNSHIP SCHOOL

DNR ACCESSIBILITY GRADING SYSTEM

1. None of the facilities meet accessibility guidelines
2. Some of the facilities meet accessibility guidelines
3. Most facilities meet accessibility guidelines
4. The entire park meets accessibility guidelines
5. The entire park was developed using the principles of universal design

ACCESSIBILITY

The facilities were evaluated for accessibility via site visits by CUPPAD on June 24th, 2022. Tools utilized in conducting the assessments included the ADA Checklist found at ADAchecklist.org and the 2010 Standards for Accessible Design. Each facility was graded according to the scale featured above with more detailed descriptions of the facility's accessibility features and shortfalls in Appendix C. The recommended accessibility improvements were integrated into the action plan and priority project lists for the township.

WELLS TOWNSHIP PARK

1

WELLS TOWNSHIP PARK

Amenities include: An entrance sign, picnic tables, grills, trash cans, an ADA accessible bathroom, access to the Township Hall and kitchen, swimming pool (renovations to be completed summer 2023), baseball field, tennis courts, expansive mowed grassy areas. Located on County Road 426 M.5, just to the east of Arnold, MI.

10
ACRES

Accessibility: 3



2

WELLS TOWNSHIP SCHOOL OWNED AND MANAGED BY THE SCHOOL DISTRICT

Amenities include: A play structure with poured in place rubber surfacing, tire climbers, swings, and a volleyball net. Located adjacent to the Wells Township Hall + Park.

13
ACRES

Accessibility: 2



AREA PARKS

Felch Grade Rail Trail

Felch + Escanaba Townships: The Felch grade rail trail begins in Felch and runs 45 miles primarily along State Route 69. The trail is utilized by bikers, walkers, equestrians, ORVs, and snowmobiles .

Within Sands Township

Strawberry Lake Recreation Area: This 120-acre water-based recreation site is located in the central portion of the Township, about 1 mile west of M-553, near the Marquette County Fairgrounds. The park is used primarily during the summer months by Township residents for picnics, fishing, swimming, and small gatherings. Camping and open fires are prohibited in the park. Gas powered boats are not allowed on Strawberry Lake. The facilities at the site includes: shore area for fishing, two picnic tables, primitive swimming beach, undeveloped boating area, small concrete picnic area, portable toilet, small earth surfaced parking area, trash can, large trash container, small gate at the entrance of park, and large undeveloped forest area surrounding lake. Trails in the area have been designated for horseback riding.

Sands Township Forest Area: The Sands Township has 120 acres of forest available for outdoor recreation pursuits, which is located adjacent to Strawberry Lake Recreation Area and Marquette County Fairgrounds. This forest area is an undeveloped site, with an active tree planting program.

Blueberry Ridge Pathway: This pathway is located in the north-central portion of the Township, just south of the intersection of M-553 and CR-480, within the Escanaba River State Forest. This is a 15-mile trail system that is utilized by cross-country skiers, mountain bikers, and hikers. During the winter, the pathway has 1.7 miles of lighted trail available for night skiing.

Marquette County Fairgrounds: This 60-acre parcel is located in the central portion of the Township, along M-553, adjacent to the Township Forest Area. This parcel of land is the site of the county fair that is held yearly in August. Facilities at the site include: exhibition building, American Legion building, 4-H building (with kitchen and restroom), horse show arena, two cattle show rings, horse barn, poultry and small animal building, large livestock building, office building (with a kitchen and restrooms), barrier-free restroom/utility building, two storage structures, power outlets, two wells, large lighted parking area, outside speaker system, ½mile oval, dirt race track, mud drag strip, paved go-cart track, large carnival area, outside horse stalls, two outdoor pavilions, and portable bleachers. All the buildings at the site are used for storage during the winter months.

Anderson Lake: This recreational site is managed by the DNR and hosts walking trails, cross-country skiing, biking, paddling and a campground.

Escanaba River State Forest: The state of Michigan, through the Department of Natural Resources, maintains more than 7,000 acres of forest in the Township. This publicly-owned land is available for a variety of outdoor recreation pursuits.

Sandy/Gwinn Trail: A portion of the Sandy/Gwinn trail runs from Nordeen park in Gwinn to the Blueberry Ridge Pathway in Sands Township.

Within Felch Township

Community Center + Park: Located on M-69 and about 50 acres. Features a pavilion, ORV/Snowmobile trail, 2 baseball fields, horseshoes, and playground equipment.

Norway Lake Park: A 15 acre regional park located in SE corner of Felch Township. Non-motorized boats allowed and camping. Swimming, picnic areas, play equipment, a boat launch, pavilion, softball field, basketball court and benches are located on site.

Genes Lake Campground: A DNR owned facility in NW Felch Township featuring 14 rustic campsites, 2 boat launch sites, and a wildlife viewing area.

Within West Branch Township

Pickerel Lake (DNR Access Site): Contains a gravel surfaced boat ramp, toilets and parking.

West Branch State Forest Campground + DNR Access Site: Features 24 campsites, no swimming allowed, along the big west branch of the Escanaba River, walking path, carry down launching area, toilets and parking.

Lower Dam State Forest Campground + DNR Access Site: Features 5 campsites, no swimming allowed, along the big west branch of the Escanaba River, walking path, carry down launching area, toilets and parking.

Within Breen Township

Stromberg Park: Features a campground, ORV trail access, a swimming area, picnic tables, parking and a dump station.

6 COMMENTS + ISSUES SCOPING

COMMUNITY INPUT

A community survey was administered in the beginning of the planning process. The survey was distributed in paper format as well as online via SurveyMonkey.com. The survey was advertised on Facebook, made available at the local restaurant/gas station, and handed out at the community fireman's picnic. There were 58 completed surveys received and processed. The input received is illustrated in this chapter and helped define the township's priorities for future parks and recreation endeavors.

After developing the draft recreation plan, the plan was released for a 30 day public comment period. A paper copy of the plan was available for review at the township hall, local store, and the plan was posted on the township's website. Input received was reflected in the action plan items and priorities.

The final public input session was held as a public hearing at the Well's Township Hall.

Having an eager and enthusiastic community reinforced the township board and planning commission's priority to complete the swimming pool project and pursue additional grant funds for future projects.

RESIDENCY SURVEY

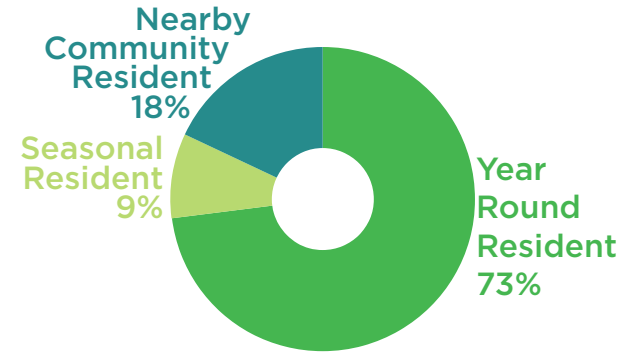

AGE | SURVEY

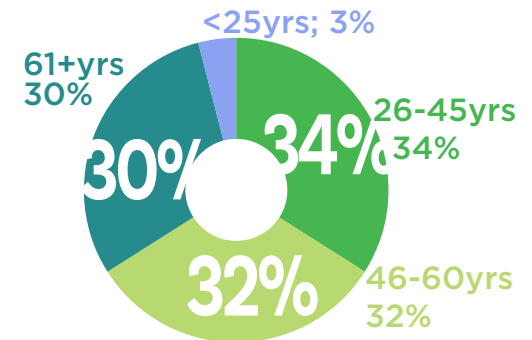

AGE | 2020

Source: US Census ACS Data

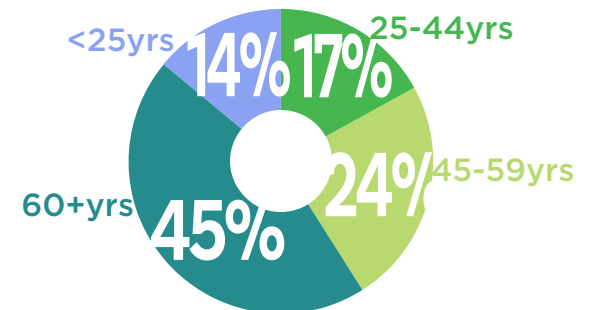

WELLS TOWNSHIP, MARQUETTE COUNTY

SURVEY RESULTS

IN THE PAST TWO YEARS, WHAT RECREATIONAL ACTIVITIES HAVE YOU OR A MEMBER OF YOUR HOUSEHOLD PARTICIPATED IN?

* NUMBERS INDICATE THE NUMBER OF TIMES MENTIONED IN THE SURVEY



ORV OR SXS RIDING



PLEASE SELECT THE PARKS AND RECREATION PROJECTS YOU WOULD LIKE TO SEE HAPPEN WITHIN WELLS TOWNSHIP.

BIKING TRAILS WOULD BRING REVENUE AND HEALTHY RESPECTABLE INDIVIDUALS TO OUR AREA. MOST RESPECT THE AREA AND LEAVE NO TRACE UNLIKE SIDE BY SIDES AND 4 WHEELERS.

-LOCAL RESIDENT

“LEAVE THE CITY PEOPLE WHERE THEY ARE.”
-LOCAL RESIDENT

Accessible Swimming Pool



20%

A Splash Pad



14%

Community Bike Trail



14%

A Pickleball Court



5%

Updated Playground



10%

Ping Pong or Cornhole OR HORSE SHOE PIT



9%

A Shade Shelter



8%

An Exercise Area



6%

- Other: List your idea!
- CAMPGROUND (3)
 - TENNIS COURT (1)
 - INDOOR POOL (1)

Disk Golf Course



10%

Mini Golf Course



10%

4% “SET ASIDE AND PROTECT LARGE AREAS OF WILD LAND, IF POSSIBLE, WITH ONLY A FEW SIMPLE FOOT TRAILS AND NO MOTORS ALLOWED.”
-LOCAL RESIDENT



7

VALUES, GOALS, & OBJECTIVES

STATEWIDE GOALS

Michigan's Statewide Outdoor Recreation Plan (SCORP) serves as the backbone for recreation planning within the state. Every five years new surveys are administered, sites studied and outdoor recreation habits mapped. Through developing a clear understanding of how people recreate within Michigan we can help define how to provide additional access and amenities for those utilizing the parks within our communities.

The main objectives outlined in the current SCORP plan:

- Foster stewardship and conservation
- Improve collaboration between stakeholders
- Raise awareness of outdoor recreation opportunities
- Improve recreational access for all
- Provide quality experiences
- Enhance health benefits
- Enhance prosperity via supporting economic prosperity, talent retention and high quality of life

RECREATION TRENDS

Nationally, many of the more traditional recreation activities, such as camping and fishing, have seen a slight decrease while nature based and backcountry activities are on the rise. Some of these trending activities include:

- Hiking
- Backpacking
- Kayaking
- Cross-country skiing
- BMX/Mountain biking
- Stand-up Paddling

Many passive recreation activities are also very popular, as noted in the SCORP surveys including relaxing, walking, picnicking, and unstructured play.

COMMUNITY VALUES

The Wells Township survey asked participants to note reasons why they valued the recreational resources within their community. A diagram on the following page features the most popular responses. These community values, paired with the question what one wished to see change within their community helped form the recreation goals. The community values for Wells Township are as follows:

VALUES

- We value having wide open spaces to explore
- We value existing recreation resources + the promise of a community pool
- We value having access to motorized and non-motorized trails

SCORP GOAL

Protect and manage Michigan's diverse and abundant natural and cultural assets to provide relevant, quality experiences that meet the fun, relaxation, and health needs of Michigan's residents and visitors and support economic prosperity.

-SCORP 2018-2022

SURVEY RESULTS

WHAT DO YOU VALUE ABOUT WELLS TOWNSHIP'S RECREATION OPPORTUNITIES?

VALUES

"LEAVE IT THE WAY IT IS WHERE WE KEEP PEOPLE AWAY AND KEEP OUR SANITY."
-LOCAL RESIDENT

Nature⁽⁶⁾ Pool⁽¹¹⁾

Trails⁽⁶⁾ Community⁽³⁾ Free⁽²⁾ Access⁽⁵⁾

Beauty⁽³⁾ Clean⁽²⁾ Not Crowded⁽⁴⁾ Off Road Trail Riding⁽⁶⁾

Opportunities⁽³⁾

Pavilion/
Park⁽⁷⁾

VALUES

"MANY ACRES OF PAPER COMPANY LAND OPEN FOR PUBLIC USE."
-LOCAL RESIDENT

"THE ABILITY OF RECREATION INFRASTRUCTURE TO BUILD AND STRENGTHEN COMMUNITIES AND PROVIDE THE PLATFORM FOR HEALTHY LIVING."
-LOCAL RESIDENT

* THE LARGER THE FONT THE MORE FREQUENTLY MENTIONED

WELLS TOWNSHIP SURVEY RESULTS

CHANGE REQUESTS

When prompted with the question what they would like to see change within parks and recreation in Wells Township, survey participants' top request was to see the pool fixed. Additional trail development both motorized and non motorized was also a frequent request. Images paired with the number of requests received are featured to the right.

These responses helped shape the priority projects for the community's action plan.

WHAT WOULD YOU LIKE TO CHANGE ABOUT WELLS TOWNSHIP'S RECREATION OPPORTUNITIES?

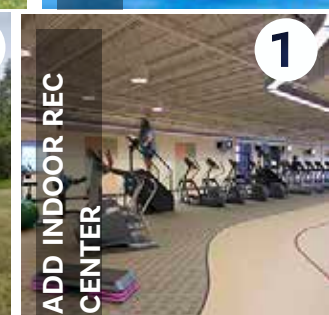

**"MORE
ACCESS FOR
THOSE WITH
DISABILITIES."**
-LOCAL RESIDENT

**"CREATE
AN AREA
TO TUBE AND
KAYAK."**
-LOCAL
RESIDENT

**"MORE
MOUNTAIN
BIKING AND TRAIL
INFRASTRUCTURE,
INCLUDING JUMP
TRAILS, PUMP TRACK,
AND SKILLS AREA."**
-SURVEY PARTICIPANT

COMMUNITY GOALS + OBJECTIVES

Parks and trails provide a connection between natural places and people with the intent of creating meaningful outdoor experiences. The evidence of these experiences is validated in the recreation values and activities listed in the surveys submitted. In addition to the value regarding recreation opportunities and access there are the equally important values regarding exquisite scenery, pristine landscapes and quiet surroundings. This inherent tension between recreation and preservation helps shape how communities choose to pursue future parks and recreation opportunities.

The boxes to the right feature the 5-Year Parks and Recreation Goals for Wells Township. The existing township park is a priority for recreation enhancements. Increased access to natural areas via trail infrastructure is another community priority. The Action Plan in Chapter 10 includes a list of future community projects.

Goal 1: Repair the community pool and better utilize the Township property.

Goal 2: Embrace opportunities to create and maintain access to the abundant wilderness within the township.

Goal 3: Promote non-motorized and motorized trail development while preserving quiet and pristine natural spaces.

OBJECTIVES

- Develop a comprehensive site design for the township park integrating universal design principles.
- Map out locations to provide improved access and trail development within the community.
- Promote partnerships between those who may assist with education, preservation and developing recreation access to the community's natural resources.
- Pursue funding opportunities to complete priorities.

8

ACTION PLAN

PRIORITY PROJECTS

Wells Township only owns and manages one recreational property but there is great potential for improvement. Looking to the survey feedback, values and goals a plan of action was developed for the community's future in recreational facility development and programming.

By no means is the chart below a comprehensive list of recreation projects as interests, demographics, and the environment are constantly evolving. The community will continue to revisit their recreation plan within future years and amend these priorities as needed.

WELLS TOWNSHIP PARK

Complete the renovation of the community pool incorporating a shade structure and ADA access. The shelter could double as a site for hosting community exercise classes.

Consider adding a disc golf course, nature trail, exercise stations, and additional recreational options throughout the township property.

Convert the underutilized tennis courts into pickleball courts or other sport courts depending on the community preference.

Continue to evaluate a location for a winter skating rink with lighting. Provide a warming space, outdoor grills, and promote community gatherings.

Consider reducing the amount of mowed park area with a mowed walking loop throughout. Work with community volunteers or the school to convert sections of the un-mowed property into prairie and pollinator habitat.

Consider adding a small rustic campground utilizing existing park resources including the shower and restroom facilities.

COMMUNITY CONNECTOR MULTI-USE TRAIL

If the opportunity presents itself, work with the community, local landowners, and potential funding sources to develop a non-motorized community connector trail.

Region

Progress on parking deck demolition



The parking deck in Houghton is pictured. The project to demolish the structure on Lakeshore Drive will be part of a larger project to rehabilitate the area. (Daily Mining Gazette file photo)

By GARRETT NEESE
Daily Mining Gazette

HOUGHTON — The Lakeshore Drive Corridor Rehabilitation Project, including the demolition of the 45-year-old Lakeshore Drive parking deck, will be bid out in about five weeks. City Manager Eric Waara told the Houghton City Council Wednesday.

MEDC will provide consultation to businesses connected to the Lakeshore Drive deck, tentatively scheduled for early February. An architectural firm and business consultants will be among the delegation. Waara said. This week, Waara has also been meeting with businesses located along Lakeshore Drive to discuss the project. People and businesses with parking passes will be given alternate city parking spots.

In an email to properties along Lakeshore Drive, Waara said demolition is planned to take between six to eight weeks, and is hoped to be completed before summer. Engineers plan to begin demolition on the east side by Huron Street. The west section between Dodge and Quincy streets will remain in use while the first part is taken down.

In July, the council voted to begin the process of tearing down the deck and deciding what will replace it. In the long term, the city will use a public engagement process to determine what kind of project might go on the former deck property. In the immediate future, the deck area will be repaved and placed as street-level parking.

The project also includes placemaking elements and other improvements along Lakeshore Drive aimed at drawing people to the area. Rain gardens, planting areas and trees will be added at spaces around the former parking deck.

Stuewaaks on the south side of Lakeshore Drive will be widened, while they will be added on the north side. The sidewalks will first new seating and gathering areas. A new pedestrian corridor starting between Michigan Made and the Print Shop will enable access between Sheldon Avenue and Lakeshore Drive. New stairs will be installed from the parking lots to the waterfront trail.

There will be periodic limited access and traffic reroutes during construction. The plan is to be finished late summer or early fall.

The approximately \$2.3 million project will be financed through a \$1 million MEDC Revitalization and Placemaking (RAP) grant, with the city borrowing an estimated \$1.3 million.

At the next council's next meeting, Waara said, he will discuss with the council what amount the city will do for a bond. In February, the council directed Waara to begin pursuing a \$1 million bond to begin the teardown of the deck.

CITY OF ISHPEMING REQUEST FOR PROPOSALS STRATEGIC COMMUNICATIONS AGENT

The City of Ishpeming is seeking proposals from experienced and qualified Strategic Communications Agents/Agency. Agents shall be in located the Upper Peninsula (preferably Marquette County) and shall identify as a strategic communications firm (not solely marketing / branding). Qualified firms will have expertise in communication for municipal/local units of government including experience in crisis communication, managing social media relations, media relationship building, and public relations.

Interested parties should respond to the requirements outlined in the Request for Proposals (RFP). A copy of the RFP may be obtained at Ishpeming City Hall, 100 E. Division Street, Ishpeming, MI 49848. Phone: 906-465-1091. Ext 203.

Proposals should be submitted to the City Manager's Office in a sealed envelope clearly marked "Strategic Communications Agent" no later than 4:00 p.m. on Thursday, January 26, 2023. The City reserves the right to reject any or all bids.



Pine Creek Woodworking in Breitung Township, was established a year ago to offer a place to practice the woodworking trade in the community. From left, in front are Norm Verley, first member Dave Wender and board president Tom Wender; in back are board members Albert Santoni, Ted Fometti, Steve Leonard, John Fortier, Steve Pontbri- and and Mark Pugh. (Daily News photo)

Pine Creek wood shop ready to launch

By TERRI CASTELAZ
The Daily News

BREITUNG TOWNSHIP — A retired building trades teacher's vision to develop a local, nonprofit woodworking facility is in sight.

Pine Creek Woodworking in Breitung Township will officially open its doors to the public at 9 a.m. Saturday, Jan. 21. Tom Wender and a group of dedicated volunteers have spent the past year refurbishing the century-old schoolhouse as a place to utilize one-of-a-kind art equipment, as well as learn the trade of woodworking.

"We told people we would be open in January — and we made it," said Wender, president of the nonprofit group.

Pine Creek Woodworking's board members are excited about the completion and believe the new nonprofit will be a great asset to the community.

The board recently awarded an honorary membership to Norm Verley, who will lead one of the first classes. "It's a place to come and create something out of a piece of wood with their own hands — and feel good about it," Wender said. "It's very gratifying." It's also about the camaraderie of being together and helping one another, Wender added. "It's a

"These classes will be part of building, 10-foot dining room tables," he added. Members are welcome to bring their own lumber or can purchase it at the facility. Area expert craftsmen will start classes in February, including wood turning, engraving, basic cabinetry, basic carpentry and picture framing. These will be free for members, while non-members can pay a fee at the door.

NOTICE OF PUBLIC HEARING WELLS TOWNSHIP MARQUETTE COUNTY

FRIDAY, JANUARY 27, 2023 7:00 P. M.
38295 County Road 426,
Arnold MI 49819



Wells Township Planning Commission is in the final process of updating its five-year recreation plan. Thank you to everyone who responded to the survey. Input from the community is crucial in planning for recreational opportunities within the township. Please consider attending the public hearing or submit your written opinions to the addresses below before January 30, 2023.

38295 County Road 426, Arnold, MI 49819
jmineau.treasurer@gmail.com

WELLS TOWNSHIP APPENDIX A Public Notice Public Hearing

CITY OF MUNISING PLANNING COMMISSION NOTICE OF PUBLIC HEARING

Notice is hereby given that the City of Munising Planning Commission will conduct a public hearing in the Commission Chambers of City Hall, located at 301 E. Superior St., Munising, Michigan, on **Wednesday, January 25, 2023, 4:00 p.m.**, for the purpose of hearing the following **Conditional Use Permit**:

For the purpose of hearing the following **Conditional Use Permit for Short Term Rental**:

For: Scott & Jennifer Dusseau, at 1110 E. Munising Ave., Munising, MI 49862

Scott & Jennifer Dusseau are applying for a Conditional Use Permit to use this property as a short-term rental. This property is Zoned Lakefront Commercial (LC)

The Conditional Use Permit, the City of Munising Zoning Ordinance, and Zoning Map, application and site plan are available to be obtained electronically by contacting me at Lubilly@CityofMunising.org

Public Comment will be taken in writing at the Clerk's office until the close of business on the day prior to the hearing, or in person at the public hearing. For further information please contact the Munising City Hall, at (906) 387-2085.

This notice is given in compliance with Act No. 267 of the Public Acts of Michigan, 1976 and Munising Zoning Ordinance.

Public Notice

**Michigan Department of Health and Human Services
Behavioral and Physical Health and
Aging Services Administration**

Alternative Benefit Plan State Plan Amendment Request

The Michigan Department of Health and Human Services (MDHHS) plans to submit an Alternative Benefit Plan (ABP) State Plan Amendment (SPA) request to the Centers for Medicare & Medicaid Services (CMS) to remove prior authorization requirements from denture services and add dental therapist as a dental provider.

WELLS TOWNSHIP

APPENDIX A

Public Notice Affidavit

The Mining Journal

Upper Michigan's Largest Daily Newspaper
249 W. Washington St., P.O. Box 430, Marquette, Michigan 49855. Phone (906)228-2500. Fax (906)228-3273.
AFFIDAVIT OF PUBLICATION

STATE OF MICHIGAN

AFFIDAVIT OF PUBLICATION

For the County of: **MARQUETTE**

In the matter of: Notice of Public Hearing
Wells Township
Five-Year Recreation Plan
January 27, 2023

Size: 2 x 4.5

State of **MICHIGAN**, County of Marquette ss.

ANN TROUTMAN

being duly sworn, says that she is

PUBLISHER

of **THE MINING JOURNAL**

a newspaper published and circulated in
said county and otherwise qualified
according to Supreme Court Rule; that
annexed hereto is a printed copy of a
notice which was published in said
newspaper on the following date, or
dates, to-wit

January 17, 2023



ANN TROUTMAN

Subscribed and sworn to before me this 17th day of January, 2023.



HOLLY GASMAN

Notary Public for MARQUETTE County, Michigan
Acting in the County of Marquette
My commission expires: May 25, 2025

WELLS TOWNSHIP
APPENDIX A
Public Notice Affidavit

The Mining Journal

Upper Michigan's Largest Daily Newspaper
249 W. Washington St., P.O. Box 430, Marquette, Michigan 49855. Phone (906)228-2500. Fax (906)228-3273.
AFFIDAVIT OF PUBLICATION

STATE OF MICHIGAN

AFFIDAVIT OF PUBLICATION

For the County of: **MARQUETTE**

In the matter of: Wells Township Planning Commission
Five-Year Recreation Plan Draft

Size: 2 x 3

State of **MICHIGAN**, County of Marquette ss.

ANN TROUTMAN

being duly sworn, says that she is

PUBLISHER

of **THE MINING JOURNAL**

a newspaper published and circulated in
said county and otherwise qualified
according to Supreme Court Rule; that
annexed hereto is a printed copy of a
notice which was published in said
newspaper on the following date, or
dates, to-wit

December 28, 2022



ANN TROUTMAN

Subscribed and sworn to before me this 24th day of January, 2023.

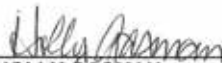

HOLLY GASMAN
Notary Public for MARQUETTE County, Michigan
Acting in the County of Marquette
My commission expires: May 25, 2025

WELLS TOWNSHIP

APPENDIX A

Meeting Minutes

WELLS TOWNSHIP-MARQUETTE COUNTY

MINUTES

Special Meeting – Wells Township Board

Date/Time: January 27, 2023 7:35 p.m.

Location: 38295 Co. Rd. 426, Arnold, Michigan

In attendance:

Town Board: R. Therrian, J. Mineau, S. Mileski

Absent: M. Manninen, P. Manninen

Planning Commission: B. Roberts, C. Brady, C. Sunholm

Public: B. Erickson and P. Mineau

- Special meeting called to order by Supervisor Therrian at 7:35 p.m.
- Roll call taken.
- S. Mileski, Trustee and board representative to the Planning Commission, moved to adopt revised draft (1/26/23) as the final draft of the Five-Year Recreation Plan prepared by Julia Cogger of CUPPAD (deleting references to rails-to-trails program, and adding nature trail enhancements and campground); seconded by R. Therrian; motion carried.
- Resolution of Adoption read aloud by J. Mineau and vote taken; resolution adopted by Board.
- S. Mileski moves to adjourn special meeting; R. Therrian seconded; special meeting/public hearing adjourned at 7:42 p.m.

Minutes taken by: Janell Mineau

WELLS TOWNSHIP-MARQUETTE COUNTY

MINUTES

Special Meeting/Public Hearing

Date/Time: January 27, 2023 7:04 p.m.

Location: 38295 Co. Rd. 426, Arnold, Michigan

In attendance:

Town Board: R.Therrian, J.Mineau, S.Mileski

Absent: M. Manninen, P. Manninen

Planning Commission: B.Roberts, C.Brady, C.Sunholm

Public: B.Erickson and P.Mineau

- Special meeting/public hearing called to order by Supervisor Therrian at 7:04 p.m.
- Roll call taken.
- S. Mileski moves for approval of agenda; J.Mineau seconded; agenda approved.
- S. Mileski, Trustee and board representative to the Planning Commission, presented revised draft (1/26/23) of the Five-Year Recreation Plan prepared by Julia Cogger of CUPPAD (deleting references to rails-to-trails program, and adding nature trail enhancements and campground.) **No objections raised.**
- Discussions regarding: ADA compliance; campground; access to school gym, land use agreement and liability for both town and school.
- S.Mileski moves to adjourn special meeting/public hearing; R.Therrian seconded; special meeting/public hearing adjourned at 7:30 p.m.

Minutes taken by: Janell Mineau

WELLS TOWNSHIP

APPENDIX A

Survey Results

Wells Township | Recreation Plan Survey

July, 2022

Your Voice Matters! Wells Township has begun the process of drafting their 5 Year Recreation Plan. Citizen input is an integral part of the planning process. Please complete the following questionnaire. Your responses are anonymous and will be reported in group form only. The survey can also be completed online here:

<https://www.surveymonkey.com/r/VK6YWZS>



If you prefer paper format, please return your completed paper survey to:

CUPPAD

Wells Township Rec Plan
2950 College Ave
Escanaba, MI 49829

We will be accepting survey responses until August 31st, 2022.

Thank you!

Please circle one of the answers below.

1. Please select what best describes your residency:

- a. Year round resident
- b. Seasonal resident
- c. Nearby community resident (Live outside Township limits)
- d. None of the above

2. Are you?

- a. Less than 25yrs old
- b. 26-45yrs old
- c. 46-60yrs old
- d. 61 and over

3. In the past two years, what recreational activities have you or a member of your household participated in?

4. What do you VALUE about Wells Township's recreation opportunities?

5. What would you like to CHANGE about Wells Township's recreation opportunities?

6. What should be a priority when addressing the Township's recreation opportunities?

(1: Highest, 2: Moderate, 3: Lowest)

- Maintenance and continuous improvement of facilities and parks
- Ensuring recreational facilities are accessible to all residents
- Development of amenities such as restrooms, night lighting, potable water, and electricity
- Other (please specify)

7. Please select the parks and recreation projects you would like to see within Wells Township.

Accessible Swimming Pool



A Splash Pad



Community Bike Trail



A Pickleball Court



Updated Playground



Ping Pong or Cornhole



A Shade Shelter



An Exercise Area

Other: List your idea!



Disk Golf Course



Mini Golf Course



Horse Shoe Pit

8. How would you like to be contacted regarding upcoming public meetings, planning document reviews, or workshops? (Please provide email address or mailing address depending on your preference)

Q1 Please select what best describes your residency:

Answered: 49 Skipped: 1

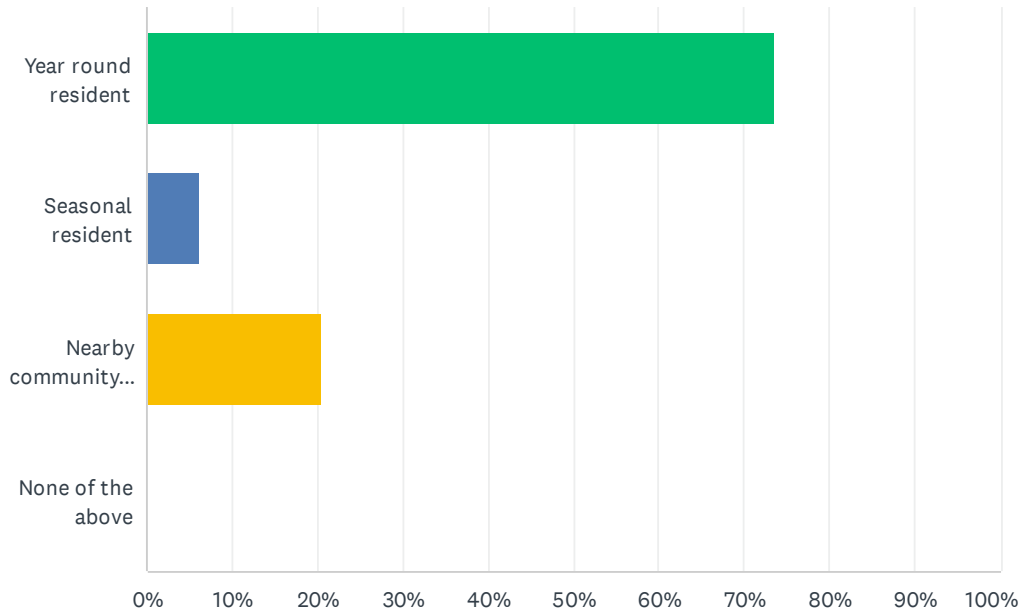

Q2 Are you:

Answered: 50 Skipped: 0

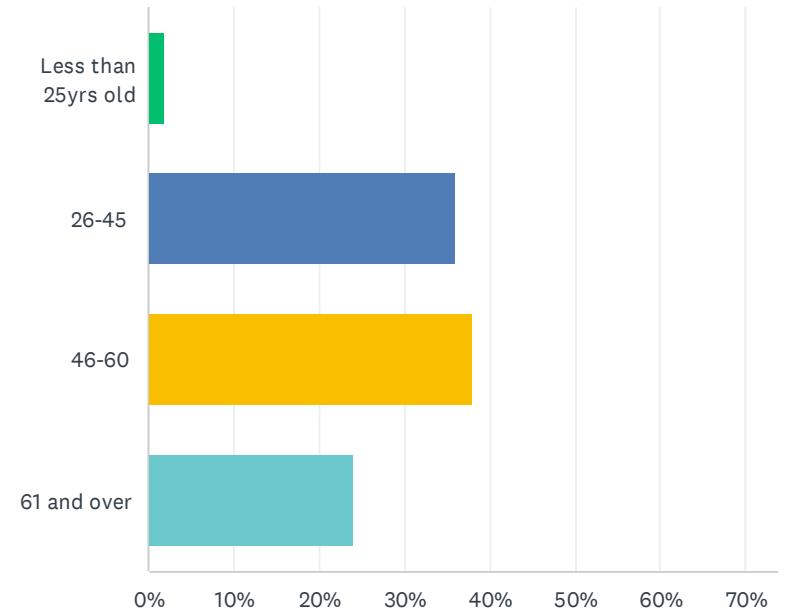

Q3 In the past two years, what recreational activities have you or a member of your household participated in?

Answered: 48 Skipped: 2

Q4 What do you VALUE about Wells Township's recreation opportunities?

Tally of VALUE question responses:

Answered: 44 Skipped: 6

Nature 6
Trails 6
Beauty 3
School/Community 3 "The ability of recreation infrastructure to build and strengthen communities and provide the platform for healthy living."
Accessibility 5
Off road trail riding 6 "Many acres of paper company land open for public use"
Pool 11
Pavilion/Picnic Area/Park 7
Opportunities 3
Waterways 1
Cleanliness 2
Tennis 1
Nothing 1
Not Crowded 4 "Leave it the way it is where we keep people away and keep our sanity"
Basketball 1
Cost 2
CHANGE
Disturb as little as possible
Pool fixed 10
More Non-Motorized Trails 5 "More mountain biking and trail infrastructure, including jump trails, pump track, and skills area"
Waterfront Recreation 4 "Create an area to tube and kayak" fishing access
Trailhead with Parking/Motorized Trails 4
Disk Golf Course 3
Nothing 5
Indoor rec center 1
Fewer People/less development 4
"Better utilization of our current facility."
More 6 "More access for those with disabilities"
Larger Playground and Track
Campground 2

Q5 What would you like to CHANGE about Wells Township's recreation opportunities?

Answered: 41 Skipped: 9

Q6 What should be a priority when addressing Wells Township's Recreation Plan? (1: Highest priority, 2: Moderate Priority, 3: Lowest Priority)

Answered: 49 Skipped: 1

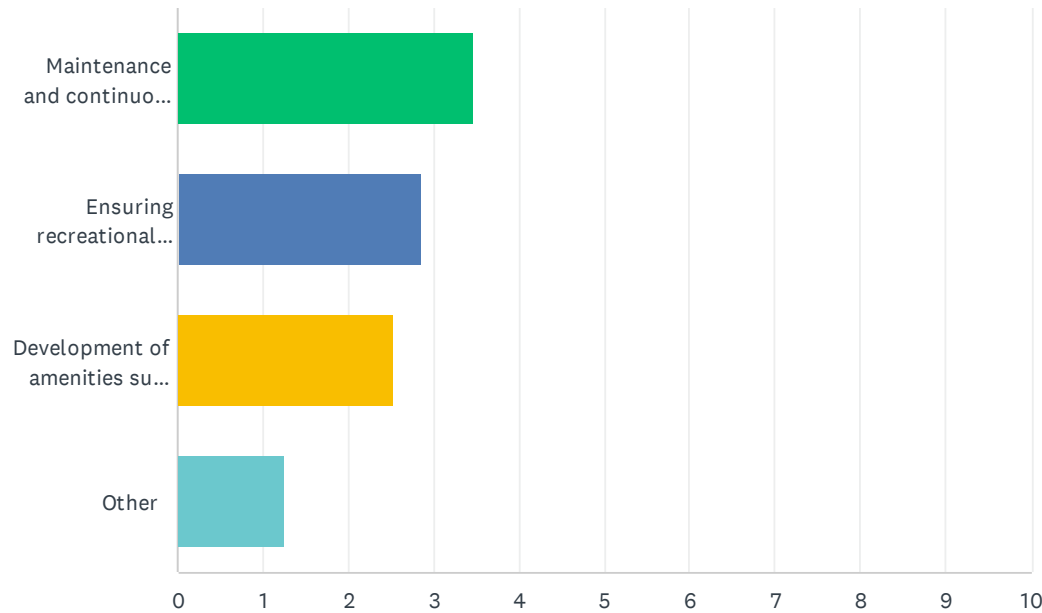

	1	2	3	4	TOTAL	SCORE
Maintenance and continuous improvement of facilities and parks	68.89% 31	13.33% 6	13.33% 6	4.44% 2	45	3.47
Ensuring recreational facilities are accessible to all residents	20.45% 9	47.73% 21	29.55% 13	2.27% 1	44	2.86
Development of amenities such as restrooms, night lighting and electricity	10.87% 5	36.96% 17	47.83% 22	4.35% 2	46	2.54
Other	5.26% 2	2.63% 1	5.26% 2	86.84% 33	38	1.26

Q7 If you listed other in question 6 please provide your priority when addressing the Township's recreation opportunities.

Answered: 19 Skipped: 31

Q8 Please select the parks and recreation projects you would like to see within Wells Township.

Answered: 48 Skipped: 2

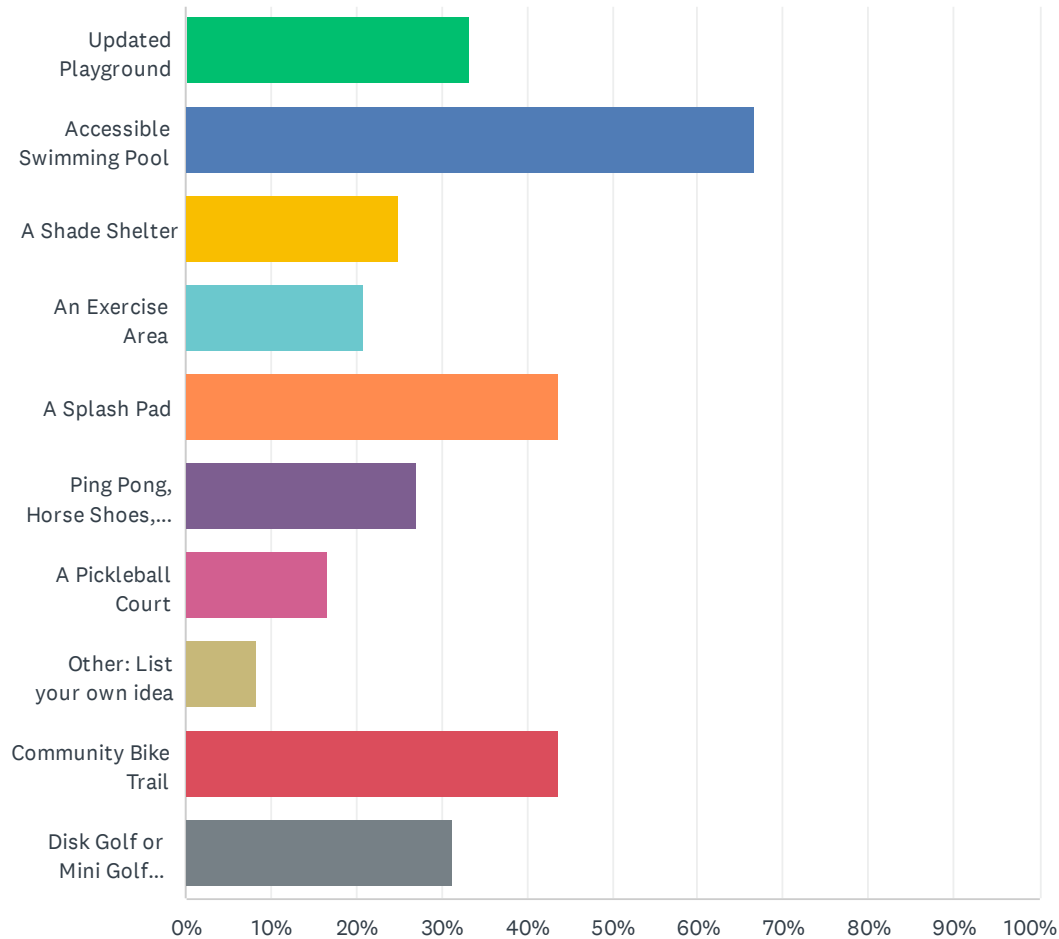

Q9 If you listed Other please elaborate:

Q10 Would you like to be contacted regarding upcoming public meetings or workshops? (Please provide email address or mailing address depending on your preference)

WELLS TOWNSHIP | APPENDIX B

Grant History



GRANTS MANAGEMENT
Michigan Department of Natural Resources

Thursday, January 26, 2023

GRANT HISTORY

Grantee

Wells Township - Marquette - Marquette County

Project No. BF90-220 **Project County:** Marquette **Project Year:** 1990
Project title: Wells Recreation Paving
Project Status: Grant Closed **Grant Amount:**
\$20,800.00

Scope Item

Concrete
Excavation and fill
Pavilion
Rebar
Remesh

Project Description: A pavilion to be multiple use, serving as a picnic area in the summer and an outdoor ice rink in the winter times.

Project No. 26-01576 **Project County:** Marquette **Project Year:** 2001
Project title: Tennis Court Improvements
Project Status: Grant Closed **Grant Amount:**
\$20,000.00

Scope Item

Barrier-free path and gate
Removal, new base and surface/2 tennis courts

Project Description: Resurface and re-mark existing courts.

Total number of projects: 2

Total Amount of Grant Given \$40,800.00



**PUBLIC OUTDOOR RECREATION GRANT
POST-COMPLETION SELF-CERTIFICATION REPORT**

*This information required under authority of Part 19, PA 451 of 1994, as amended;
the Land and Water Conservation Fund Act of 1965, 78 Stat. 897 (1964); and Part 715, of PA 451 of 1994, as amended.*

GRANT TYPE: MICHIGAN NATURAL RESOURCES TRUST FUND CLEAN MICHIGAN INITIATIVE
(Please select one) LAND AND WATER CONSERVATION FUND RECREATION PASSPORT BOND FUND

GRANTEE: Wells Township Marquette Co.
PROJECT NUMBER: BF90-220 PROJECT TYPE: (1990) Recreation
PROJECT TITLE: Wells Recreation Pavilion
PROJECT SCOPE: Pavilion for multiple use

TO BE COMPLETED BY LOCAL GOVERNMENT AGENCY (GRANTEE)

Name of Agency (Grantee)	Contact Person	Title
<u>Wells Township - Marquette Co.</u>	<u>Robert Therrion</u>	<u>Supervisor</u>
<u>38295 County Road 426</u>	<u>906-238-4355</u>	
<u>Arnold MI 49819</u>	<u>fishing3461@yahoo.com</u>	

SITE DEVELOPMENT

Any change(s) in the facility type, site layout, or recreation activities provided?
If yes, please describe change(s). Yes No
picnic tables added; electricity added; hydrant added
School utilized for summer concerts and activities

Has any portion of the project site been converted to a use other than outdoor recreation? If yes, please describe what portion and describe use. (This would include cell towers and any non-recreation buildings.) Yes No

Are any of the facilities obsolete? If yes, please explain. Yes No

SITE QUALITY

Is there a park entry sign which identifies the property or facility as a public recreation area? If yes, please provide a photograph of the sign. If no, please explain. Yes No

Are the facilities and the site being properly maintained? If no, please explain. Yes No

Is vandalism a problem at this site? If yes, explain the measures being taken to prevent or minimize vandalism. Yes No

POST COMPLETION SELF-CERTIFICATION REPORT - CONT'D

Is maintenance scheduled on a regular basis? If yes, give schedule. If no, please explain. Yes No

As needed by town hall custodian

GENERAL

Is a Program Recognition plaque permanently displayed at the site? If yes, please provide a photograph. (Not required for Bond Fund Grants) Yes No N/A

Is any segment of the general public restricted from using the site or facilities? (i.e. resident only, league only, boaters only, etc.) If yes, please explain. Yes No

Is a fee charged for use of the site or facilities? If yes, please provide fee structure. Yes No

What are the hours and seasons for availability of the site?

All

COMMENTS (ATTACH SEPARATE SHEET IF MORE SPACE IS NEEDED)



POST COMPLETION SELF-CERTIFICATION REPORT - CONT'D

CERTIFICATION

I do hereby certify that I am duly elected, appointed and/or authorized by the Grantee named above and that the information and answers provided herein are true and accurate to the best of my personal knowledge, information and belief.

Robert Thompson
Please print

Robert Thompson
Grantee Authorized Signature

1-27-23
Date

Jane Mironau
Please print

Jane Mironau
Witness Signature

1-27-23
Date

Send completed report to: **POST COMPLETION GRANT INSPECTION REPORTS**
GRANTS MANAGEMENT
MICHIGAN DEPARTMENT OF NATURAL RESOURCES
PO BOX 30405
LANSING MI 48909-7925



**PUBLIC OUTDOOR RECREATION GRANT
POST-COMPLETION SELF-CERTIFICATION REPORT**

This information required under authority of Part 19, PA 451 of 1994, as amended; the Land and Water Conservation Fund Act of 1965, 78 Stat. 697 (1964); and Part 715, of PA 451 of 1994, as amended.

GRANT TYPE: MICHIGAN NATURAL RESOURCES TRUST FUND CLEAN MICHIGAN INITIATIVE
(Please select one) LAND AND WATER CONSERVATION FUND RECREATION PASSPORT BOND FUND

GRANTEE: Wells Township-Marquette County

PROJECT NUMBER: 26-01576 PROJECT TYPE: (2001) Recreation

PROJECT TITLE: Tennis Court Improvements

PROJECT SCOPE: Resurface and remark

TO BE COMPLETED BY LOCAL GOVERNMENT AGENCY (GRANTEE)

Name of Agency (Grantee)	Contact Person	Title
<u>Wells Township-Marquette</u>	<u>Robert Therian</u>	<u>Supervisor</u>
Address	Telephone	
<u>38295 County Road 426</u>	<u>906-238-4355</u>	
City, State	Email	
<u>Arnold MI 49819</u>	<u>fishing3461@yahoo.com</u>	

SITE DEVELOPMENT

Any change(s) in the facility type, site layout, or recreation activities provided?
If yes, please describe change(s).

Yes No

Has any portion of the project site been converted to a use other than outdoor recreation? If yes, please describe what portion and describe use. (This would include cell towers and any non-recreation buildings.)

Yes No

Are any of the facilities obsolete? If yes, please explain.

deteriorization of surface

Yes No

SITE QUALITY

Is there a park entry sign which identifies the property or facility as a public recreation area? If yes, please provide a photograph of the sign. If no, please explain.

Yes No

Are the facilities and the site being properly maintained? If no, please explain.

Yes No

Is vandalism a problem at this site? If yes, explain the measures being taken to prevent or minimize vandalism.

Yes No

POST COMPLETION SELF-CERTIFICATION REPORT - CONT'D

Is maintenance scheduled on a regular basis? If yes, give schedule. If no, please explain.

As needed

Yes No

GENERAL

Is a Program Recognition plaque permanently displayed at the site? If yes, please provide a photograph. (Not required for Bond Fund Grants)

Yes No N/A

Is any segment of the general public restricted from using the site or facilities? (i.e. resident only, league only, boaters only, etc.) If yes, please explain.

Yes No

Is a fee charged for use of the site or facilities? If yes, please provide fee structure.

Yes No

What are the hours and seasons for availability of the site?

All

COMMENTS (ATTACH SEPARATE SHEET IF MORE SPACE IS NEEDED)



POST COMPLETION SELF-CERTIFICATION REPORT - CONT'D

CERTIFICATION

I do hereby certify that I am duly elected, appointed and/or authorized by the Grantee named above and that the information and answers provided herein are true and accurate to the best of my personal knowledge, information and belief.

Robert Therrian
Please print

Robert Therrian
Grantee Authorized Signature

1-27-23
Date

Jared Mincan
Please print

Jared Mincan
Witness Signature

1-27-23
Date

Send completed report to: POST COMPLETION GRANT INSPECTION REPORTS
GRANTS MANAGEMENT
MICHIGAN DEPARTMENT OF NATURAL RESOURCES
PO BOX 30425
LANSING MI 48909-7925

WELLS TOWNSHIP

APPENDIX C

GUIDELINES FOR DESIGNING ADA COMPLIANT AND UNIVERSALLY ACCESSIBLE PARKS

Michigan DNR Guidelines

ACCESSIBLE TRAILS

- WALKWAYS WITHIN A SITE** - minimum 6 foot width and slopes under 2%
- MULTI-USE TRAIL** - 8 feet, with slopes under 2%, wider width so two people can walk side by side or people can pass
- REGIONAL TRAIL SYSTEM** - at least 10 feet wide, with 1-foot buffers on either side, with slopes under 2%
- SURFACE TREATMENT** - unitary surface (ex. concrete, boardwalk or asphalt, crushed aggregate/screenings that have been “stabilized” or natural soils enhanced with soil stabilizers)
- TRANSITIONS** - plates between trail and pedestrian bridges, decks, etc.
- INTERSECTIONS** - contrasting color treatment and textured surface treatments such as brushed concrete at intersections or interpretive stations to cue people who have vision impairments that there is something to pay attention to at that spot
- Close to level cross slopes (side to side) and very gentle running slopes, no steep sections, larger (greater than 60”X60”) level areas at all turns and intersections
- Thoughtfully laid out on the site to maximize the experience with minimal difficulty
- AMENITIES** - All should be accessible including: benches, restrooms (port-a-johns), drinking fountains, etc.

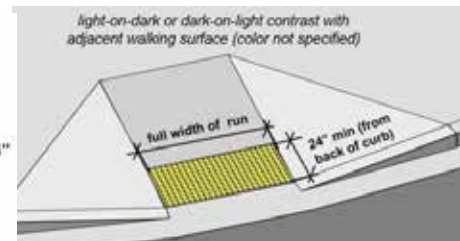
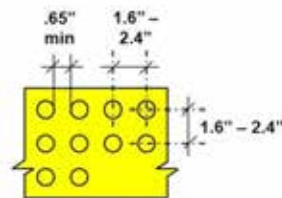
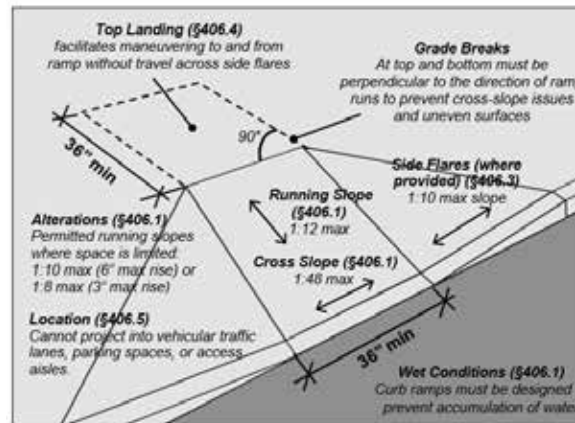
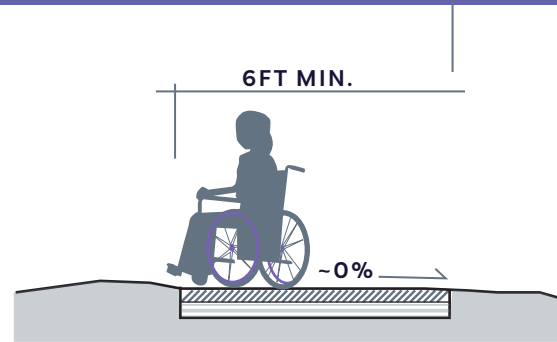

WELLS TOWNSHIP

GUIDELINES FOR DESIGNING ADA COMPLIANT AND UNIVERSALLY ACCESSIBLE PARKS

- BEACH**
- Routes over the beach and into the water, can be portable/temporary matting if it needs to be taken in and out for beach cleaning/ dragging or in the off season
 - Wide enough for side by side walking/passing
 - At beach route end have an accessible area at the waters edge large enough to park multiple chairs while the owners are in the water
 - With a transfer system at the waters edge so people can get down to the ground level and into the water.



TRANSFER STATION

- FISHING DOCK + VIEWING DECK**
- More than 25% of the rails are lowered in various locations or no rails at all with only an edge treatment to prevent roll off
 - Sitting benches (all with backs and arm rests) scattered about so anglers can choose to sit or stand to fish
 - Tackle box stands next to one bench end (not both) leaving one end clear space for sitting side by side with someone in a wheelchair
 - A variety of fish landing cutaways strategically placed
 - A variety of accessible opportunities—over-water fishing, shore fishing, in-water fishing, etc.
 - Transition plates between access route and deck/pier

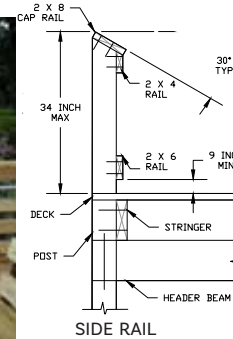

- CAMPING**
- Accessible surface on all sites, including rustic sites
 - Larger spaces to accommodate side lifts on campers and vehicles
 - Accessible tables, grills (15" minimum, 34" maximum height), and fire rings on all sites
 - Centrally located restrooms on easy routes from each site



WELLS TOWNSHIP

GUIDELINES FOR DESIGNING ADA COMPLIANT AND UNIVERSALLY ACCESSIBLE PARKS

SKIING + SLEDDING HILL

- Accessible route to top (no steps), possibly using a “magic carpet” lift
- Level surface for sled mounting at hill top
- If staffed, provide ATV transport or have policy that allows personal ATV use
- Transfer at hill bottom to help transfer down to sled and back up into chair/walker



<https://www.movingmountainsap.org/>

SPORT COURTS + FIELDS

- Routes to both sides of all fields and courts, not just end zones
- Accessible seating spaces both ground level and elevated if risers/bleachers are provided
- Accessible seating spaces scattered throughout all viewing areas and levels with companion seating on both sides of the space
- All lowered service windows at all concession areas
- Wider gate openings into court areas (tennis, bocce, basketball) and skate parks to accommodate wider sports wheelchairs
- Routes to both horseshoe pits and along both sides of the route between pits
- Level routes onto bocce courts with sitting benches at both ends



MAGIC CARPET LIFT



WELLS TOWNSHIP

GUIDELINES FOR DESIGNING ADA COMPLIANT AND UNIVERSALLY ACCESSIBLE PARKS

PLAYGROUNDS

- Has both ramp and transfer access to all play components
- Ramps to every “getting on spot” or “sit/stand & do it spot” of every play component
- Transfer system from the ground up to the main deck located near the exits of slides and climbers furthest from the ramp onto the structure
- Only unitary safety surface such as poured-in-place or rubber tiles NOT any loose fill materials likes shredded rubber, wood chips, engineered wood fiber, or any other non-unitary surface material
- On deck transfer platform at the entry point of every slide
- On deck transfer platform with one open transfer side and one side with transfer steps to every entry/exit point of every climber, so kids climbing up can get down to the deck to move to another component, as they may have left an assistive device at the ground
- A good variety of things to manipulate that make noise or music, have high contrast/bright colors, games that two kids can play (to foster social interaction), Braille and sign language panels to teach awareness, easy to operate with just one hand with a whole fist (does not require tight/pinch/grasp/wrist twist to operate)
- Different high contrast colors for decks versus transfers so kids with low vision can perceive a change in level
- Play panels are located at heights so they can be used from a seated position or standing



WELLS TOWNSHIP

GUIDELINES FOR DESIGNING ADA COMPLIANT AND UNIVERSALLY ACCESSIBLE PARKS

BOARDWALKS

- (A) -6 foot minimum width so two people can walk side by side or people can pass
- (B) -EDGE TREATMENT to prevent roll/step off
- (C) -SIDE RAILS - more than 25% must be lowered for easy viewing in various places along the boardwalk
- INTERPRETIVE INFORMATION - in a variety of alternative formats such as auditory, large print, Braille, pictures, etc.

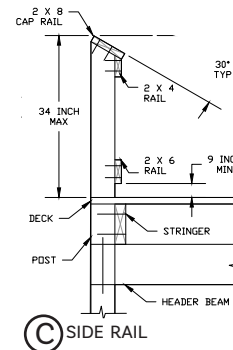
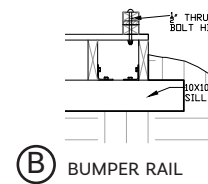
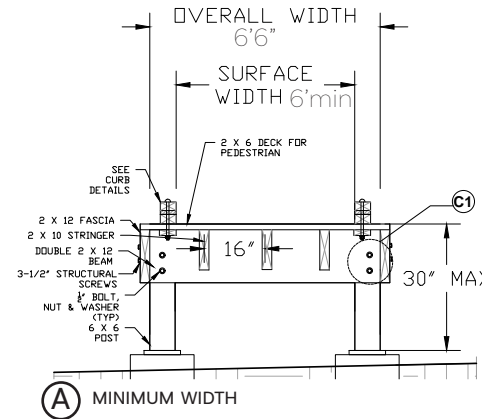

NATURE CENTER

- INTERPRETIVE INFORMATION -in a variety of alternative formats such as auditory, large print, Braille, pictures, etc.
- TECHNOLOGY - Creative use such as mp3 players for auditory descriptions (this gives the info. directly to the individual) closed loop assistive listening devices and closed circuit captioning of all interpretive presentations
- All displays at lowered heights for sitting or standing viewing
- All operating mechanisms that are operable with one hand and do not require tight/pinch/grasp/wrist twist to operate

PARKING

- More than minimum number of accessible spots
- Each connected directly to an accessible route to the park elements and NOT into the traffic flow
- Thoughtfully located nearest the activity entrance, which might require multiple lots (some near the beach, some near the playground, some near the bathhouse, etc.)

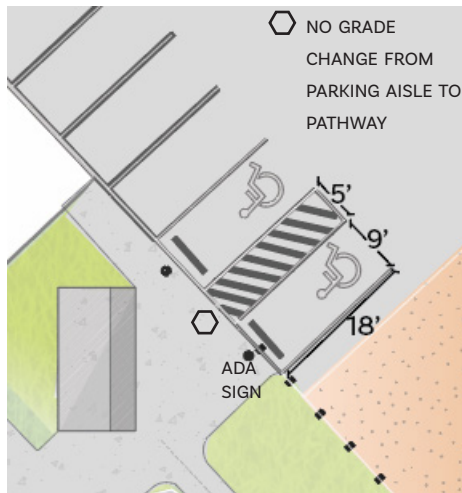

WELLS TOWNSHIP

AMERICAN WITH DISABILITIES ACT (ADA)

Quick reference of minimum requirements for accessible spaces. The 2010 American with Disabilities Act Standards for Accessible Design Guidelines provide a comprehensive resource. https://www.ada.gov/2010ADASTandards_index.htm

- Clear width is 36” min for most accessible routes
- Surfaces: 1/4” max change, slopes less than 5%, firm and stable
- Head Clearance: 80” high and as wide as the route
- Clear Space: min 30” wide by 48” deep located at element
- Viewing: clear from 32”-51” height
- Maneuvering space: 60”x60” min and level, at entries and places for change of direction
- Transferable height: 17”-19” with transfer supports
- Knee Clearance: 27” high by 30” wide by 25” deep
- Table tops, counters, and rail heights: max 34” high
- Reach range: 48” max height forward and 15” min low side
- Operation: operating mechanism that is operable with one hand and does not require tight pinch/grasp/wrist twist to open

The following page features a closer look at the Wells Township parks. These sites have been assigned an accessible rating derived from this scale.

The Michigan DNR Rating Chart is as Follows:

- 1 | NONE OF THE FACILITIES MEET ACCESSIBILITY GUIDELINES**
- 2 | SOME OF THE FACILITIES MEET ACCESSIBILITY GUIDELINES**
- 3 | MOST OF THE FACILITIES MEET ACCESSIBILITY GUIDELINES**
- 4 | THE ENTIRE PARK AREAS MEET ACCESSIBILITY GUIDELINES**
- 5 | THE ENTIRE PARK WAS DEVELOPED USING UNIVERSAL DESIGN PRINCIPLES**

WELLS TOWNSHIP

WELLS TOWNSHIP PARK ACCESSIBILITY RATING: 3



Wells Township has done an excellent job of making sure their community facilities are ADA accessible. The township hall, pavilion, restrooms, tennis courts, and basketball court all have level, paved pathways for access. There are a few minor improvements proposed below:

RESTROOMS

- Although the restrooms themselves are accessible, the handles on the doors should be replaced with a handle that does not require gripping and twisting. Another option is to prop the doors open when the restrooms are open for use.
- The water source adjacent to the restroom would not be considered ADA accessible. An accessible drinking fountain/bottle filling station may be a good alternative.

PARKING

- The proper number of ADA parking spaces should be signed with the international sign of accessibility mounted at least 60 inches above the finished surface. There should also be a striped aisle for accessing the vehicle.